

# Technical Information

## Micropilot FMR56, FMR57

Free space radar

### Level measurement in bulk solids

#### Application

- Continuous, non-contact level measurement in powdery to granular bulk solids
- PP-cladded horn antenna (FMR56); horn or parabolic antenna (FMR57)
- Maximum measuring range: 70 m (230 ft)
- Temperature:  $-40$  to  $+400$  °C ( $-40$  to  $752$  °F)
- Pressure:  $-1$  to  $+16$  bar ( $-14.5$  to  $+232$  psi)
- Accuracy:  $\pm 3$  mm
- International explosion protection certificates
- Linearity protocol (3-point, 5-point)

#### Your benefits

- Reliable measurement even for changing product and process conditions
- HISTOROM data management for easy commissioning, maintenance and diagnostics
- Highest reliability due to Multi-Echo Tracking
- SIL2 according to IEC 61508, SIL3 in case of homogeneous or heterogeneous redundancy
- Seamless integration into control or asset management systems
- Intuitive user interface in national languages
- Easy proof test for SIL



## Table of contents

<b>Important document information</b> . . . . .	<b>4</b>	<b>Process</b> . . . . .	<b>49</b>
Symbols . . . . .	4	Process temperature, Process pressure . . . . .	49
<b>Function and system design</b> . . . . .	<b>6</b>	Dielectric constant . . . . .	50
Measuring principle . . . . .	6	<b>Mechanical construction</b> . . . . .	<b>51</b>
<b>Input</b> . . . . .	<b>8</b>	Dimensions . . . . .	51
Measured variable . . . . .	8	Weight . . . . .	61
Measuring range . . . . .	8	Materials: GT18 housing . . . . .	62
Operating frequency . . . . .	9	Materials: GT19 housing . . . . .	63
Transmitting power . . . . .	9	Materials: GT20 housing . . . . .	64
<b>Output</b> . . . . .	<b>10</b>	Materials: Antenna and process connection . . . . .	65
Output signal . . . . .	10	Materials: Weather protection cover . . . . .	68
Signal on alarm . . . . .	11	<b>Operability</b> . . . . .	<b>69</b>
Linearization . . . . .	11	Operating concept . . . . .	69
Galvanic isolation . . . . .	11	Local operation . . . . .	69
Protocol-specific data . . . . .	11	Operation with remote display and operating module FHX50 . . . . .	70
<b>Power supply</b> . . . . .	<b>16</b>	Remote operation . . . . .	70
Terminal assignment . . . . .	16	System integration via Fieldgate . . . . .	74
Device plug connectors . . . . .	23	<b>Certificates and approvals</b> . . . . .	<b>75</b>
Supply voltage . . . . .	24	CE mark . . . . .	75
Power consumption . . . . .	26	C-Tick symbol . . . . .	75
Current consumption . . . . .	26	Ex approval . . . . .	75
Power supply failure . . . . .	27	Dual seal according to ANSI/ISA 12.27.01 . . . . .	75
Potential equalization . . . . .	27	Functional Safety . . . . .	75
Terminals . . . . .	27	WHG . . . . .	75
Cable entries . . . . .	27	Pressure Equipment Directive . . . . .	75
Cable specification . . . . .	27	Marine certificate (in preparation) . . . . .	75
Overvoltage protection . . . . .	28	Radio standard EN302729-1/2 . . . . .	75
<b>Performance characteristics</b> . . . . .	<b>29</b>	Radio standard EN302372-1/2 . . . . .	76
Reference operating conditions . . . . .	29	FCC / Industry Canada . . . . .	76
Maximum measured error . . . . .	29	Japanese radio approval . . . . .	77
Measured value resolution . . . . .	29	CRN approval . . . . .	77
Reaction time . . . . .	30	Track record . . . . .	77
Influence of ambient temperature . . . . .	30	Test, Certificate . . . . .	78
<b>Installation</b> . . . . .	<b>31</b>	Other standards and guidelines . . . . .	79
Installation conditions . . . . .	31	<b>Ordering information</b> . . . . .	<b>80</b>
Measuring conditions . . . . .	35	Ordering information . . . . .	80
Installation in vessel (free space) . . . . .	36	3-point linearity protocol . . . . .	81
Vessels with heat insulation . . . . .	42	5-point linearity protocol . . . . .	82
<b>Environment</b> . . . . .	<b>43</b>	Customized parametrization . . . . .	83
Ambient temperature range . . . . .	43	Services . . . . .	83
Ambient temperature limits . . . . .	43	<b>Accessories</b> . . . . .	<b>84</b>
Storage temperature . . . . .	47	Device-specific accessories . . . . .	84
Climate class . . . . .	47	Communication-specific accessories . . . . .	90
Altitude according to IEC61010-1 Ed.3 . . . . .	47	Service-specific accessories . . . . .	91
Degree of protection . . . . .	47	System components . . . . .	91
Vibration resistance . . . . .	47	<b>Documentation</b> . . . . .	<b>92</b>
Cleaning the antenna . . . . .	47	Standard documentation . . . . .	92
Electromagnetic compatibility (EMC) . . . . .	48	Supplementary documentation . . . . .	92
		Safety Instructions (XA) . . . . .	92

Registered trademarks ..... 96





Patents ..... 96

ТЕХНОДИЗАЙН-М







## Important document information

### Symbols









#### Safety symbols

Symbol	Meaning
	<b>DANGER!</b> This symbol alerts you to a dangerous situation. Failure to avoid this situation will result in serious or fatal injury.
	<b>WARNING!</b> This symbol alerts you to a dangerous situation. Failure to avoid this situation can result in serious or fatal injury.
	<b>CAUTION!</b> This symbol alerts you to a dangerous situation. Failure to avoid this situation can result in minor or medium injury.
	<b>NOTE!</b> This symbol contains information on procedures and other facts which do not result in personal injury.



#### Electrical symbols

Symbol	Meaning	Symbol	Meaning
	Direct current		Alternating current
	Direct current and alternating current		<b>Ground connection</b> A grounded terminal which, as far as the operator is concerned, is grounded via a grounding system.
	<b>Protective ground connection</b> A terminal which must be connected to ground prior to establishing any other connections.		<b>Equipotential connection</b> A connection that has to be connected to the plant grounding system: This may be a potential equalization line or a star grounding system depending on national or company codes of practice.

#### Symbols for certain types of information

Symbol	Meaning
	<b>Permitted</b> Procedures, processes or actions that are permitted.
	<b>Preferred</b> Procedures, processes or actions that are preferred.
	<b>Forbidden</b> Procedures, processes or actions that are forbidden.
	<b>Tip</b> Indicates additional information.
	Reference to documentation
	Reference to page
	Reference to graphic
	Visual inspection

Symbols in graphics

Symbol	Meaning
1, 2, 3 ...	Item numbers
1. 2. 3. ...	Series of steps
A, B, C, ...	Views
A-A, B-B, C-C, ...	Sections
	<b>Hazardous area</b> Indicates a hazardous area.
	<b>Safe area (non-hazardous area)</b> Indicates the non-hazardous area.

ТЕХНОДИЗАЙН-М

## Function and system design

### Measuring principle

The Micropilot is a "downward-looking" measuring system, operating based on the time-of-flight method (ToF). It measures the distance from the reference point (process connection) to the product surface. Radar impulses are emitted by an antenna, reflected off the product surface and received again by the radar system.

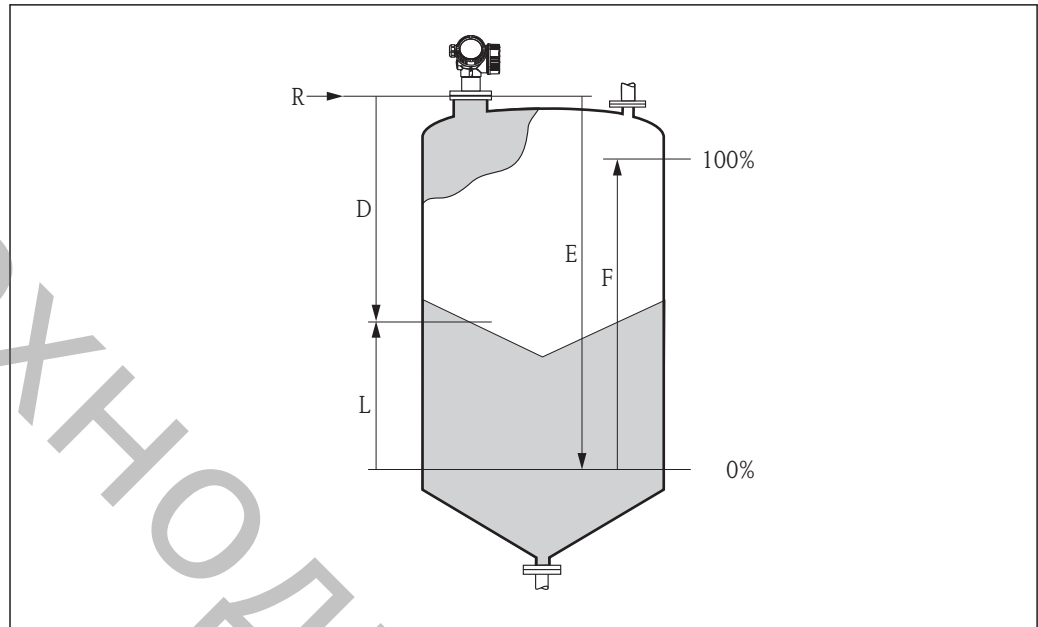

A0017872

1 Setup parameters of the Micropilot

- R Reference point of the measurement (lower edge of the flange or threaded connection)
- E Empty calibration (= zero)
- F Full calibration (= span)
- D Measured distance
- L Level ( $L = E - D$ )

### Input

The reflected radar impulses are received by the antenna and transmitted into the electronics. A microprocessor evaluates the signal and identifies the level echo caused by the reflection of the radar impulse at the product surface. The unambiguous signal identification is accomplished by the PulseMaster® eXact software together with the Multi-echo tracking algorithms, based on many years of experience with time-of-flight technology.

The distance  $D$  to the product surface is proportional to the time of flight  $t$  of the impulse:

$$D = c \cdot t/2,$$

with  $c$  being the speed of light.

Based on the known empty distance  $E$ , the level  $L$  is calculated:

$$L = E - D$$

The reference point  $R$  of the measurement is located at the process connection. For details see the dimensional drawing:

- FMR56: → 52
- FMR57: → 56

The Micropilot is equipped with functions to suppress interference echoes. The user can activate these functions. Together with the multi-echo tracking algorithms they ensure that interference echoes (i.e. from edges and weld seams) are not interpreted as level echo.

### Output

The Micropilot is commissioned by entering an empty distance "E" (=zero), a full distance "F" (=span) and application parameters which automatically adapt the instrument to the process conditions. For models with a current output, the factory adjustment for zero point "E" and span "F" is 4 mA and 20 mA. For digital outputs and the display module, the factory adjustment for zero point "E" and span "F" is 0 % and 100 %.

A linearization with max. 32 points, based on a table entered either manually or semi-automatically, can be activated locally or remotely. This function provides a measurement in engineering units and a linear output signal for spheres, horizontal cylindrical tanks and vessels with conical outlet.

### Life cycle of the product

#### Engineering

- Universal measuring principle
- Measurement unaffected by medium properties
- Hardware and software developed according to SIL IEC 61508

#### Procurement

- Endress+Hauser being the world market leader in level measurement guarantees asset protection
- Worldwide support and service

#### Installation

- Special tools are not required
- Reverse polarity protection
- Modern, detachable terminals
- Main electronics protected by a separate connection compartment

#### Commissioning

- Fast, menu-guided commissioning in only a few steps on site or from the control room
- Plain text display in national languages reduces the risk of error or confusion
- Direct local access of all parameters
- Short instruction manual at the device

#### Operation

- Multi-echo tracking: Reliable measurement through self-learning echo-search algorithms taking into account the short-term and long-term history in order to check the found echoes for plausibility and to suppress interference echoes.
- Diagnostics in accordance with NAMUR NE107

#### Maintenance

- HistoROM: Data backup for instrument settings and measured values
- Exact instrument and process diagnosis to assist fast decisions with clear details concerning remedies
- Intuitive, menu-guided operating concept in national languages saves costs for training, maintenance and operation
- Cover of the electronics compartment can be opened in hazardous areas

#### Retirement

- Order code translation for subsequent models
- RoHS-conforming (Restriction of certain Hazardous Substances), unleaded soldering of electronic components
- Environmentally sound recycling concept

## Input

### Measured variable

The measured variable is the distance between the reference point and the product surface.

The level is calculated from this distance, taking into account the empty distance "E" entered by the user.

If required, the level can be converted into other variables (volume, mass) by means of a linearization (up to 32 points).

### Measuring range

#### Maximum measuring range

Device	Maximum measuring range
FMR56	30 m (98 ft)
FMR57	70 m (230 ft)

#### Usable measuring range

The usable measuring range depends on the size of the antenna, the reflectivity of the medium, the mounting location and eventual interference reflections.

Reduction of the max. possible measuring range through:

- Media with poor reflection properties (= small DC). For examples refer to table below.
- Angle of repose
- Extremely loose surfaces of bulk solids, e.g. bulk solids with low bulk weight for pneumatic filling.
- Build-up, above all of moist products.

Media group	DK ( $\epsilon_r$ )	Examples
A	1.6 to 1.9	<ul style="list-style-type: none"> <li>▪ Plastic granulate</li> <li>▪ White lime, special cement</li> <li>▪ Sugar</li> </ul>
B	1.9 to 2.5	Portland cement, plaster
C	2.5 to 4	<ul style="list-style-type: none"> <li>▪ Grain, seeds</li> <li>▪ Ground stones</li> <li>▪ Sand</li> </ul>
D	4 to 7	<ul style="list-style-type: none"> <li>▪ Naturally moist (ground) stones, ore</li> <li>▪ Salt</li> </ul>
E	> 7	<ul style="list-style-type: none"> <li>▪ Metallic powder</li> <li>▪ Carbon black</li> <li>▪ Coal</li> </ul>

The respective lower group applies for very loose or loosened bulk solids.

**i** Dielectric constants (DC values) for many important media are summarized in

For dielectric constants (DC values) of many important media refer to:

- the **DC Manual** by Endress+Hauser (CP01076F) by Endress+Hauser
- the **DC Values** App by Endress+Hauser (available for Android and iOS)



**Operating frequency**

K-band (~ 26 GHz)

Up to 8 Micropilot transmitters can be installed in the same tank because the transmitter pulses are statistically coded.

**Transmitting power**

Distance	Average energy density in beam direction
1 m (3.3 ft)	< 64 nW/cm <sup>2</sup>
5 m (16 ft)	< 2.5 nW/cm <sup>2</sup>

ТЕХНОДИЗАЙН-М

## Output

### Output signal

#### HART

Signal coding	FSK $\pm 0.5$ mA over current signal
Data transmission rate	1 200 Bit/s
Galvanic isolation	Yes

#### PROFIBUS PA

Signal coding	Manchester Bus Powered (MBP)
Data transmission rate	31.25 kBit/s, voltage mode
Galvanic isolation	Yes

#### FOUNDATION Fieldbus

Signal coding	Manchester Bus Powered (MBP)
Data transmission rate	31.25 kBit/s, voltage mode
Galvanic isolation	Yes

### Switch output

**i** For HART devices, the switch output is available as an option. See product structure, feature 20: "Power Supply, Output", option B: "2-wire; 4-20mA HART, switch output"

Devices with PROFIBUS PA and FOUNDATION Fieldbus always have a switch output.

Switch output	
Function	Open collector switching output
Switching behavior	Binary (conductive or non-conductive), switches when the programmable switch point is reached
Failure mode	non-conductive
Electrical connection values	$U = 10.4$ to $35 V_{DC}$ , $I = 0$ to $40$ mA
Internal resistance	$R_i < 880 \Omega$ The voltage drop at this internal resistance has to be taken into account on planning the configuration. For example, the resulting voltage at a connected relay must be sufficient to switch the relay.
Insulation voltage	floating, Insulation voltage $1\ 350 V_{DC}$ to power supply and $500 V_{AC}$ to ground
Switch point	freely programmable, separately for switch-on and switch-off point
Switching delay	freely programmable from 0 to 100 sec. , separately for switch-on and switch-off point
Number of switching cycles	corresponds to the measuring cycle
Signal source device variables	<ul style="list-style-type: none"> <li>▪ Level linearized</li> <li>▪ Distance</li> <li>▪ Terminal voltage</li> <li>▪ Electronic temperature</li> <li>▪ Relative echo amplitude</li> <li>▪ Diagnostic values, Advanced diagnostics</li> </ul>
Number of switching cycles	unlimited

<b>Signal on alarm</b>	<p>Depending on the interface, failure information is displayed as follows:</p> <ul style="list-style-type: none"> <li>▪ Current output (for HART devices) <ul style="list-style-type: none"> <li>– Failsafe mode selectable (in accordance with NAMUR Recommendation NE 43): <ul style="list-style-type: none"> <li>Minimum alarm: 3.6 mA</li> <li>Maximum alarm (= factory setting): 22 mA</li> </ul> </li> <li>– Failsafe mode with user-selectable value: 3.59 to 22.5 mA</li> </ul> </li> <li>▪ Local display <ul style="list-style-type: none"> <li>– Status signal (in accordance with NAMUR Recommendation NE 107)</li> <li>– Plain text display</li> </ul> </li> <li>▪ Operating tool via digital communication (HART, PROFIBUS PA, FOUNDATION Fieldbus) or service interface (CDI) <ul style="list-style-type: none"> <li>– Status signal (in accordance with NAMUR Recommendation NE 107)</li> <li>– Plain text display</li> </ul> </li> </ul>
<b>Linearization</b>	<p>The linearization function of the device allows the conversion of the measured value into any unit of length or volume. Linearization tables for calculating the volume in cylindrical tanks are pre-programmed. Other tables of up to 32 value pairs can be entered manually or semi-automatically.</p>

**Galvanic isolation** All circuits for the outputs are galvanically isolated from each other.

**Protocol-specific data** **HART**

Manufacturer ID	17 (0x11)
Device type ID	41 (0x28)
HART specification	6.0
Device description files (DTM, DD)	<p>Information and files under:</p> <ul style="list-style-type: none"> <li>▪ <a href="http://www.endress.com">www.endress.com</a></li> <li>▪ <a href="http://www.hartcomm.org">www.hartcomm.org</a></li> </ul>
HART load	Min. 250 Ω
HART device variables	<p>The measured values can be freely assigned to the device variables.</p> <p><b>Measured values for PV (primary variable)</b></p> <ul style="list-style-type: none"> <li>▪ Level linearized</li> <li>▪ Distance</li> <li>▪ Electronic temperature</li> <li>▪ Relative echo amplitude</li> <li>▪ Analog output adv. diagnostics</li> </ul> <p><b>Measured values for SV, TV, FV (second, third and fourth variable)</b></p> <ul style="list-style-type: none"> <li>▪ Level linearized</li> <li>▪ Distance</li> <li>▪ Terminal voltage</li> <li>▪ Electronic temperature</li> <li>▪ Absolute echo amplitude</li> <li>▪ Relative echo amplitude</li> <li>▪ Area of incoupling</li> </ul>
Supported functions	<ul style="list-style-type: none"> <li>▪ Burst mode</li> <li>▪ Additional transmitter status</li> </ul>

**Wireless HART data**

<b>Minimum start-up voltage</b>	16 V
<b>Start-up current</b>	3.6 mA
<b>Start-up time</b>	40 s
<b>Minimum operating voltage</b>	12.3 V
<b>Multidrop current</b>	3.6 mA
<b>Set-up time</b>	1 s

## PROFIBUS PA

Manufacturer ID	17 (0x11)
Ident number	0x1559
Profile version	3.02
GSD file	Information and files under:
GSD file version	<ul style="list-style-type: none"> <li>▪ <a href="http://www.endress.com">www.endress.com</a></li> <li>▪ <a href="http://www.profibus.org">www.profibus.org</a></li> </ul>
Output values	<p><b>Analog Input:</b></p> <ul style="list-style-type: none"> <li>▪ Level linearized</li> <li>▪ Distance</li> <li>▪ Terminal voltage</li> <li>▪ Electronic temperature</li> <li>▪ Absolute echo amplitude</li> <li>▪ Relative echo amplitude</li> <li>▪ Analog output advanced diagnostics 1/2</li> </ul> <p><b>Digital Input:</b></p> <ul style="list-style-type: none"> <li>▪ Advanced diagnostic blocks</li> <li>▪ Status output switch block</li> </ul>
Input values	<p><b>Analog Output:</b></p> <ul style="list-style-type: none"> <li>▪ Analog value from PLC (for sensor block external pressure to compensate gas phase effects)</li> <li>▪ Analog value from PLC to be indicated on the display</li> </ul> <p><b>Digital Output:</b></p> <ul style="list-style-type: none"> <li>▪ Extended diagnostic block</li> <li>▪ Level limiter</li> <li>▪ Sensor block measurement on</li> <li>▪ Sensor block save history on</li> <li>▪ Status output</li> </ul>
Supported functions	<ul style="list-style-type: none"> <li>▪ Identification &amp; Maintenance Einfachste Geräteidentifizierung seitens des Leitsystems und des Typenschildes</li> <li>▪ Automatic Ident Number Adoption GSD compatibility mode with respect to the preceding product Micropilot M FMR2xx</li> <li>▪ Physical Layer Diagnostics Installation check of the PROFIBUS segment and the Micropilot FMR5x via the terminal voltage and telegram surveillance.</li> <li>▪ PROFIBUS Up-/Download Up to 10 times faster writing and reading of parameters via PROFIBUS up-/download</li> <li>▪ Condensed Status Simple and self-explanatory diagnostic information by categorization of occurring diagnostic messages.</li> </ul>

## FOUNDATION Fieldbus

Manufacturer ID	0x452B48
Device type	0x1028
Device Revision	0x01
DD Revision	Information and files can be found:
CFF Revision	<ul style="list-style-type: none"> <li>▪ <a href="http://www.endress.com">www.endress.com</a></li> <li>▪ <a href="http://www.fieldbus.org">www.fieldbus.org</a></li> </ul>
Device Tester Version (ITK Version)	6.0.1
ITK Test Campaign Number	IT085300
Link Master (LAS) capable	yes
Link Master / Basic Device selectable	yes; default: Basic Device

Node address	Default: 247 (0xF7)
Features supported	Following methods are supported: <ul style="list-style-type: none"> <li>▪ Restart</li> <li>▪ ENP Restart</li> <li>▪ Setup</li> <li>▪ Linearization</li> <li>▪ Self Check</li> </ul>
<b>Virtual Communication Relationships (VCRs)</b>	
Number of VCRs	44
Number of Link Objects in VFD	50
Permanent entries	1
Client VCRs	0
Server VCRs	10
Source VCRs	43
Sink VCRs	0
Subscriber VCRs	43
Publisher VCRs	43
<b>Device Link Capabilities</b>	
Slot time	4
Min. inter PDU delay	8
Max. response delay	20

*Transducer Blocks*

Block	Content	Output values
Setup Transducer Block	Contains all parameters for a standard commissioning procedure	<ul style="list-style-type: none"> <li>▪ Level or volume <sup>1)</sup> (Channel 1)</li> <li>▪ Distance (Channel 2)</li> </ul>
Advanced Setup Transducer Block	Contains all parameters for a more detailed configuration of the device	no output values
Display Transducer Block	Contains all parameters for the configuration of the display module	no output values
Diagnostic Transducer Block	Contains diagnostic information	no output values
Advanced Diagnostic Transducer Block	Contains parameters for the Advanced Diagnostic	no output values
Expert Configuration Transducer Block	Contains parameters which require detailed knowledge of the functionalities of the device	no output values
Expert Information Transducer Block	Contains information about the state of the device	no output values
Service Sensor Transducer Block	Contains parameters which can only be operated by Endress+Hauser service personnel	no output values
Service Information Transducer Block	Contains information on the state of device which is relevant for service operations	no output values
Data Transfer Transducer Block	Contains parameters which allow to backup the device configuration in the display module and to restore it into the device. Access to these parameters is restricted to the Endress+Hauser service.	no output values

1) depending on the configuration of the block

## Function Blocks

Block	Content	Number of permanent blocks	Number of instantiable blocks	Execution time	Functionality
Resource Block	The Resource Block contains all the data that uniquely identifies the field device. It is an electronic version of a nameplate of the device.	1	0	-	enhanced
Analog Input Block	The AI block takes the manufacturer's input data, selected by channel number, and makes it available to other function blocks at its output.	2	3	25 ms	enhanced
Discrete Input Block	The DI block takes a discrete input value (e.g. indication of an level limit), and makes it available to other function blocks at its output.	1	2	20 ms	standard
Mutiple Analog Output Block	This block is used to transfer analog data from the bus into the device	1	0	20 ms	standard
Mutiple Discrete Output Block	This block is used to transfer discrete data from the bus to the device.	1	0	20 ms	standard
PID Block	The PID block serves as proportional-integral-derivative controller and is used almost universally to do closed-loop-control in the field including cascade and feedforward.	1	1	25 ms	standard
Arithmetic Block	This block is designed to permit simple use of popular measurement math functions. The user does not have to know how to write equations. The math algorithm is selected by name, chosen by the user for the function to be done.	1	1	25 ms	standard
Signal Characterizer Block	The signal characterizer block has two sections, each with an output that is a non-linear function of the respective input. The non-linear function is determined by a single look-up table with 21 arbitrary x-y pairs.	1	1	25 ms	standard
Input Selector Block	The input selector block provides selection of up to four inputs and generates an output based on the configured action. This block normally receives its inputs from AI blocks. The block performs maximum, minimum, middle, average and 'first good' signal selection.	1	1	25 ms	standard

Block	Content	Number of permanent blocks	Number of instantiable blocks	Execution time	Functionality
Integrator Block	The Integrator Function Block integrates a variable as a function of the time or accumulates the counts from a Pulse Input block. The block may be used as a totalizer that counts up until reset or as a batch totalizer that has a setpoint, where the integrated or accumulated value is compared to pre-trip and trip settings, generating discrete signals when these settings are reached.	1	1	25 ms	standard
Analog Alarm Block		1	1	25 ms	standard



Up to 20 blocks can be instantiated in the device altogether, including the blocks already instantiated on delivery.

ТЕХНОДИЗАЙН-М

## Power supply

Terminal assignment

2-wire: 4-20mA HART

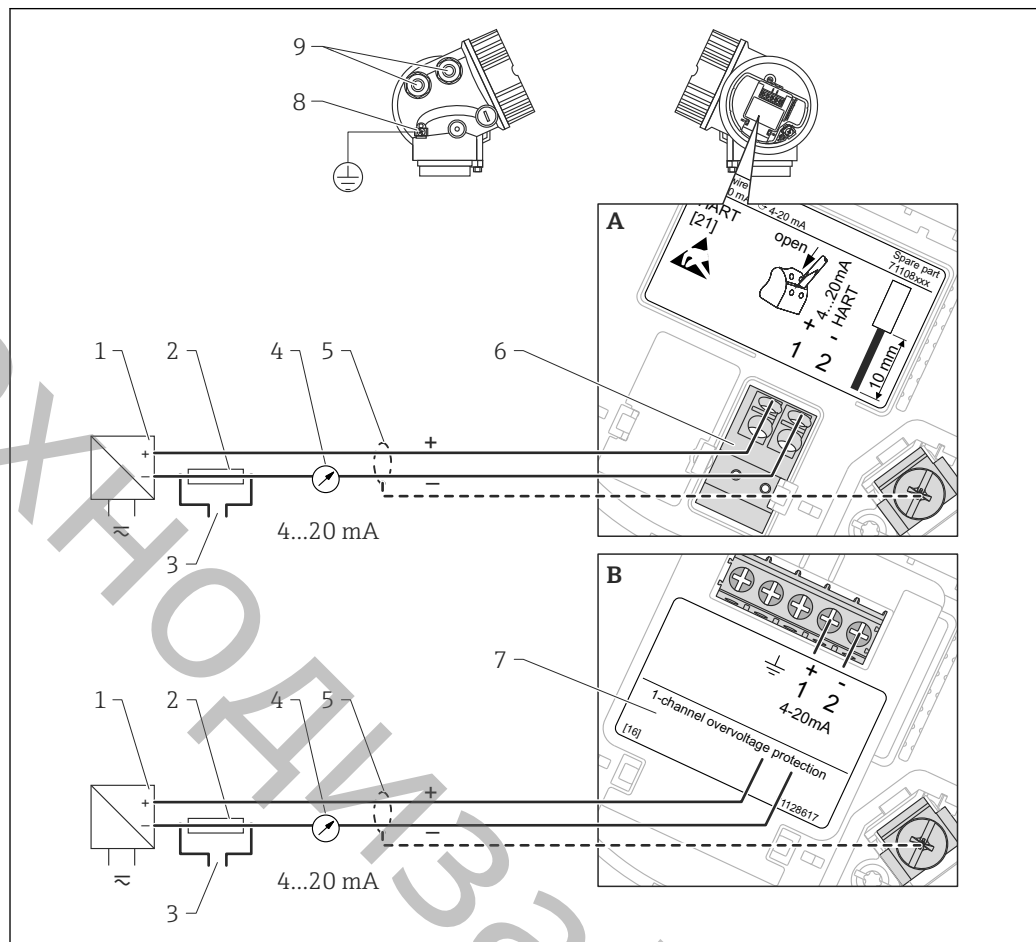

A0011294

2 Terminal assignment 2-wire; 4-20mA HART

- A Without integrated overvoltage protection  
 B With integrated overvoltage protection  
 1 Active barrier with power supply (e.g. RN221N): Observe terminal voltage  
 2 HART communication resistor ( $\geq 250 \Omega$ ): Observe maximum load  
 3 Connection for Commubox FXA195 or FieldXpert SFX350/SFX370 (via VIATOR Bluetooth modem)  
 4 Analog display device: Observe maximum load  
 5 Cable screen; observe cable specification  
 6 4-20mA HART (passive): Terminals 1 and 2  
 7 Overvoltage protection module  
 8 Terminal for potential equalization line  
 9 Cable entry



2-wire: 4-20mA HART, switch output

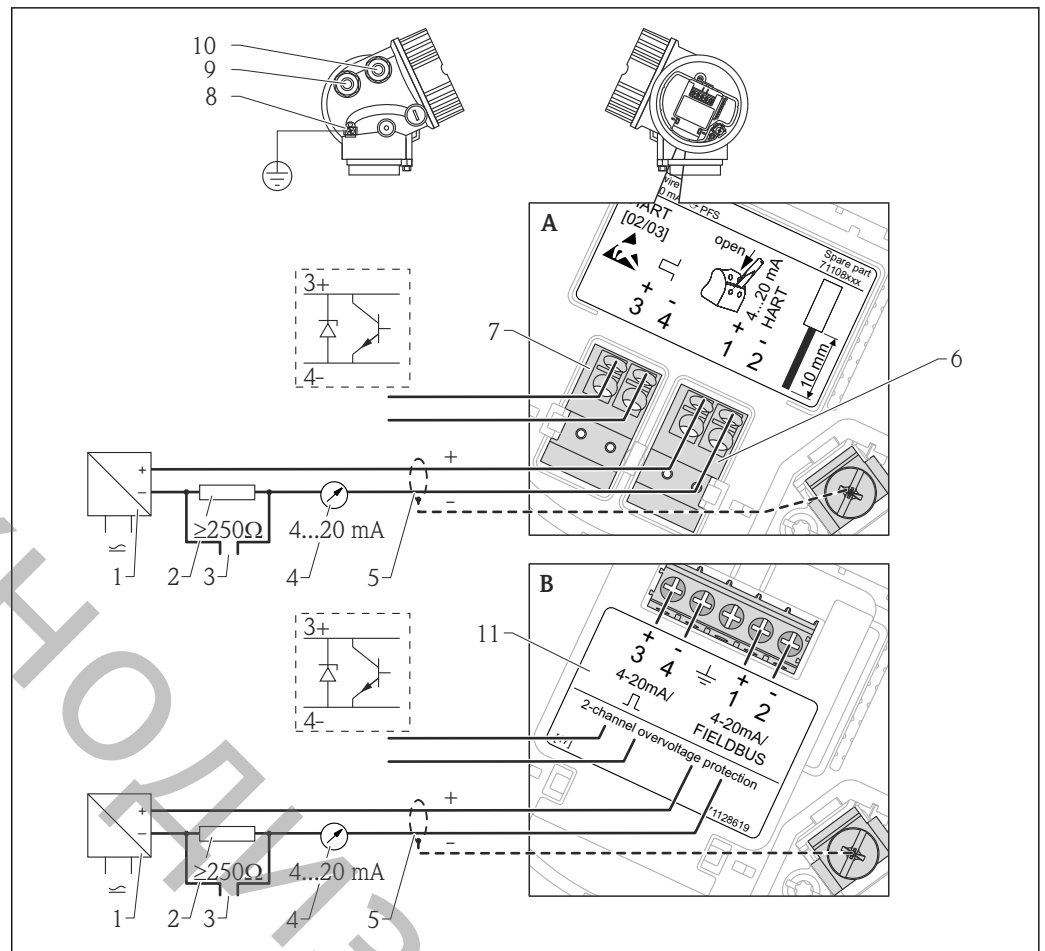

A0013759

3 Terminal assignment 2-wire; 4-20mA HART, switch output

- A Without integrated overvoltage protection
- B With integrated overvoltage protection
- 1 Active barrier with power supply (e.g. RN22 1N): Observe terminal voltage
- 2 HART communication resistor ( $\geq 250 \Omega$ ): Observe maximum load
- 3 Connection for Commubox FXA195 or FieldXpert SFX350/SFX370 (via VIATOR Bluetooth modem)
- 4 Analog display device: Observe maximum load
- 5 Cable screen; observe cable specification
- 6 4-20mA HART (passive): Terminals 1 and 2
- 7 Switch output (open collector): Terminals 3 and 4
- 8 Terminal for potential equalization line
- 9 Cable entry for 4-20mA HART line
- 10 Cable entry for switch output line
- 11 Overvoltage protection module

2-wire: 4-20mA HART, 4-20mA

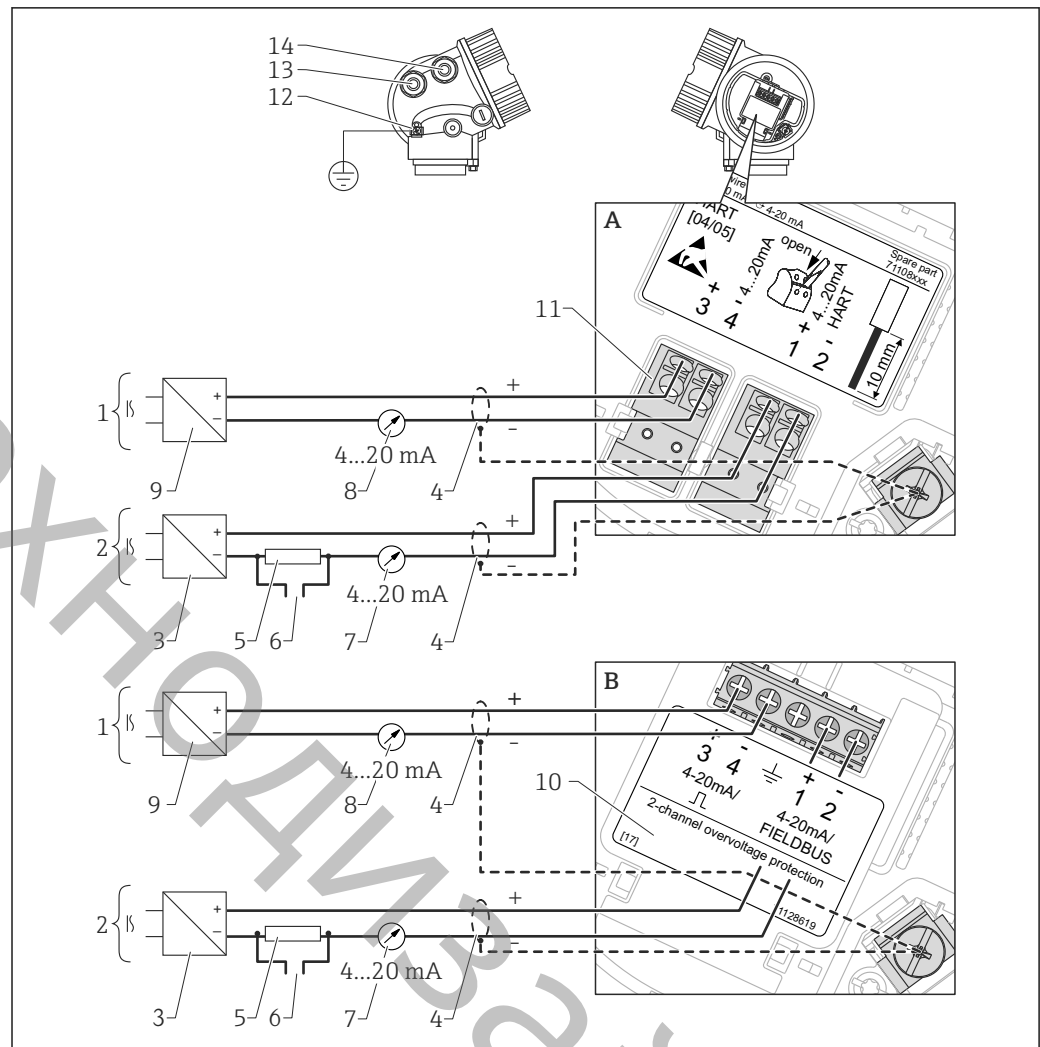

A0013923

4 Terminal assignment 2-wire, 4-20 mA HART, 4...20mA

- A Without integrated overvoltage protection
- B With integrated overvoltage protection
- 1 Connection current output 2
- 2 Connection current output 1
- 3 Supply voltage for current output 1 (e.g. RN221N); Observe terminal voltage
- 4 Cable screen; observe cable specification
- 5 HART communication resistor ( $\geq 250 \Omega$ ); Observe maximum load
- 6 Connection for Commubox FXA195 or FieldXpert SFX350/SFX370 (via VIATOR Bluetooth modem)
- 7 Analog display device ; observe maximum load
- 8 Analog display device ; observe maximum load
- 9 Supply voltage for current output 2 (e.g. RN221N); Observe terminal voltage
- 10 Overvoltage protection module
- 11 Current output 2: Terminals 3 and 4
- 12 Terminal for the potential equalization line
- 13 Cable entry for current output 1
- 14 Cable entry for current output 2

**i** This version is also suited for single-channel operation. In this case, current output 1 (terminals 1 and 2) must be used.

4-wire: 4-20mA HART (10.4 to 48 V<sub>DC</sub>)

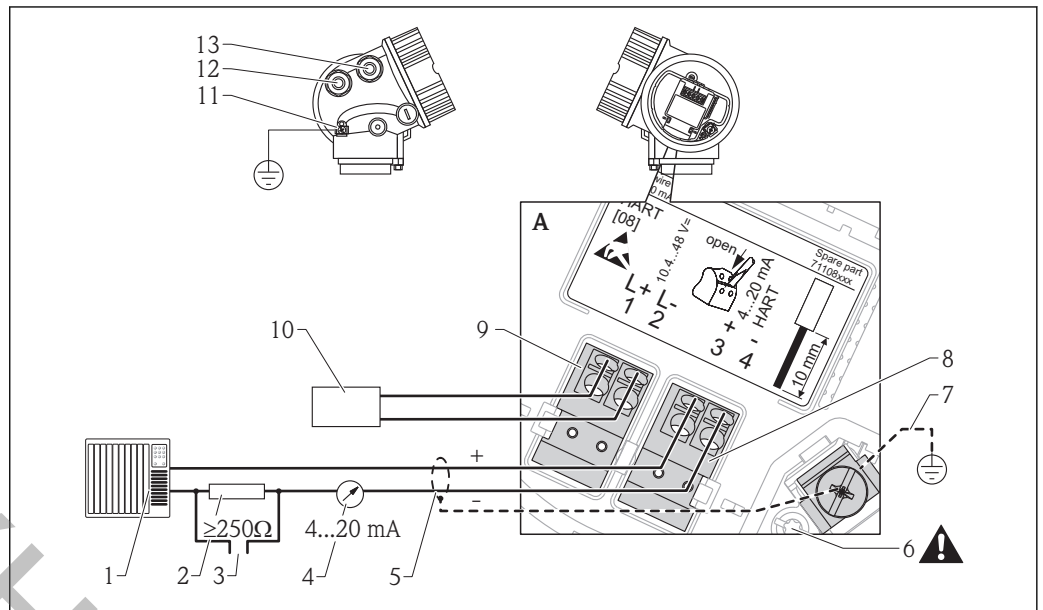

5 Terminal assignment 4-wire; 4-20mA HART (10.4 to 48 VDC)

- 1 Evaluation unit, e.g. PLC
- 2 HART communication resistor ( $\geq 250 \Omega$ ): Observe maximum load
- 3 Connection for Commubox FXA195 or FieldXpert SFX350/SFX370 (via VIATOR Bluetooth modem)
- 4 Analog display device: Observe maximum load
- 5 Signal cable including screening (if required), observe cable specification
- 6 Protective connection; do not disconnect!
- 7 Protective earth, observe cable specification
- 8 4...20mA HART (active): Terminals 3 and 4
- 9 Supply voltage: Terminals 1 and 2
- 10 Supply voltage: Observe terminal voltage, observe cable specification
- 11 Terminal for potential equalization
- 12 Cable entry for signal line
- 13 Cable entry for power supply

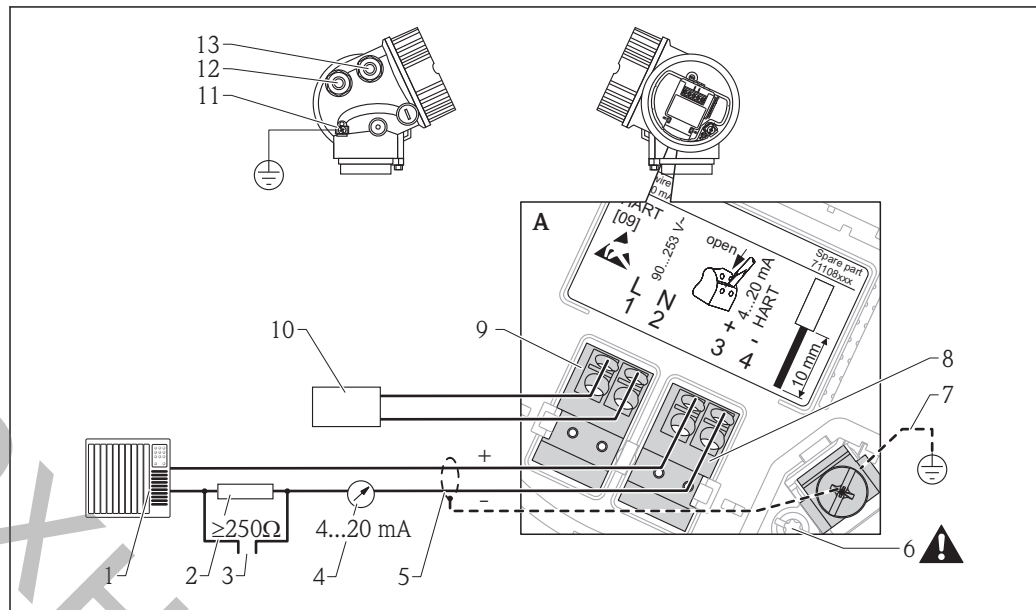
4-wire: 4-20mA HART (90 to 253 V<sub>AC</sub>)

6 Terminal assignment 4-wire; 4-20mA HART (90 to 253 VAC)

- 1 Evaluation unit, e.g. PLC
- 2 HART communication resistor ( $\geq 250 \Omega$ ): Observe maximum load
- 3 Connection for Commubox FXA195 or FieldXpert SFX350/SFX370 (via VIATOR Bluetooth modem)
- 4 Analog display device: Observe maximum load
- 5 Signal cable including screening (if required), observe cable specification
- 6 Protective connection; do not disconnect!
- 7 Protective earth, observe cable specification
- 8 4...20mA HART (active): Terminals 3 and 4
- 9 Supply voltage: Terminals 1 and 2
- 10 Supply voltage: Observe terminal voltage, observe cable specification
- 11 Terminal for potential equalization
- 12 Cable entry for signal line
- 13 Cable entry for power supply

**CAUTION**

**To ensure electrical safety:**

- ▶ Do not disconnect the protective connection (6).
- ▶ Disconnect the supply voltage before disconnecting the protective earth (7).

- i** Connect protective earth to the internal ground terminal (7) before connecting the supply voltage. If necessary, connect the potential matching line to the external ground terminal (11).
- i** In order to ensure electromagnetic compatibility (EMC): Do not only ground the device via the protective earth conductor of the supply cable. Instead, the functional grounding must also be connected to the process connection (flange or threaded connection) or to the external ground terminal.
- i** An easily accessible power switch must be installed in the proximity of the device. The power switch must be marked as a disconnecter for the device (IEC/EN61010).

PROFIBUS PA / FOUNDATION Fieldbus

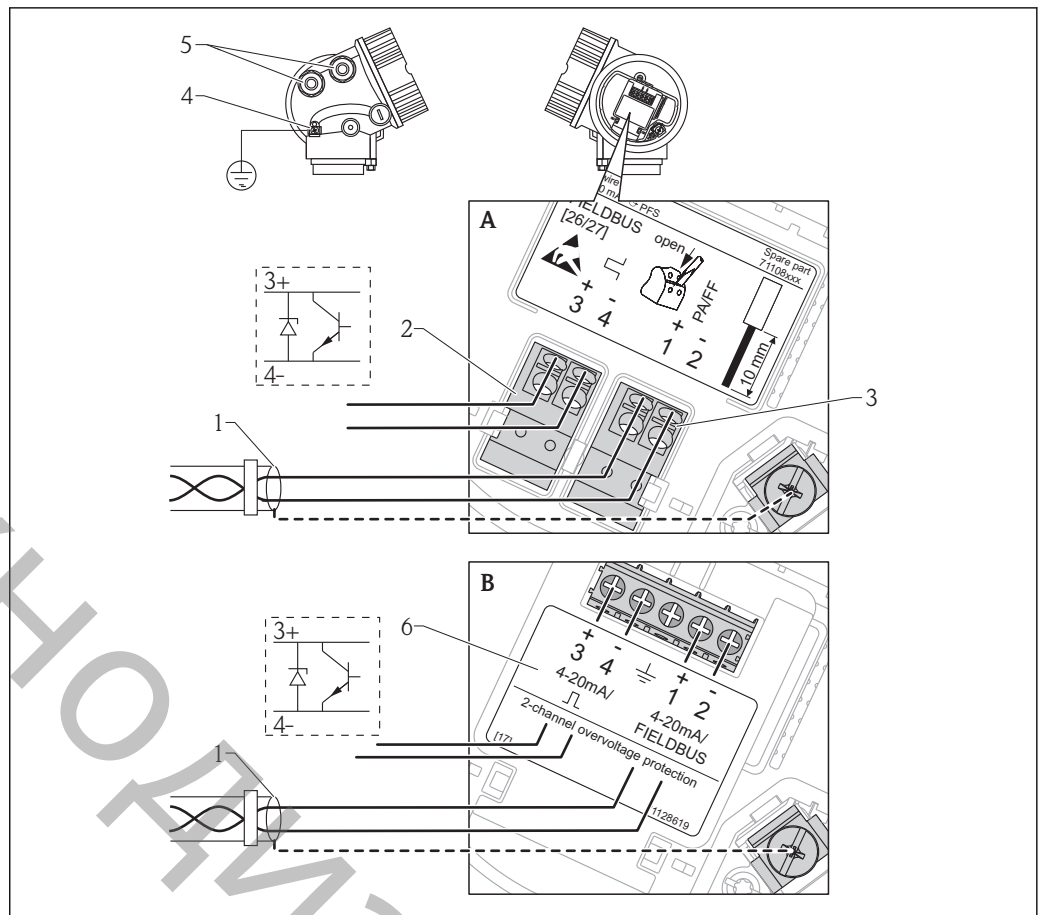

A0011341

7 Terminal assignment PROFIBUS PA / FOUNDATION Fieldbus

- A Without integrated overvoltage protection
- B With integrated overvoltage protection
- 1 Cable screen: Observe cable specifications
- 2 Switch output (open collector): Terminals 3 and 4
- 3 PROFIBUS PA / FOUNDATION Fieldbus: Terminals 1 and 2
- 4 Terminal for potential equalization line
- 5 Cable entries
- 6 Overvoltage protection module

### Connection examples for the switch output

**i** For HART devices, the switch output is available as an option. See product structure, feature 20: "Power Supply, Output", option B: "2-wire; 4-20mA HART, switch output"

Devices with PROFIBUS PA and FOUNDATION Fieldbus always have a switch output.

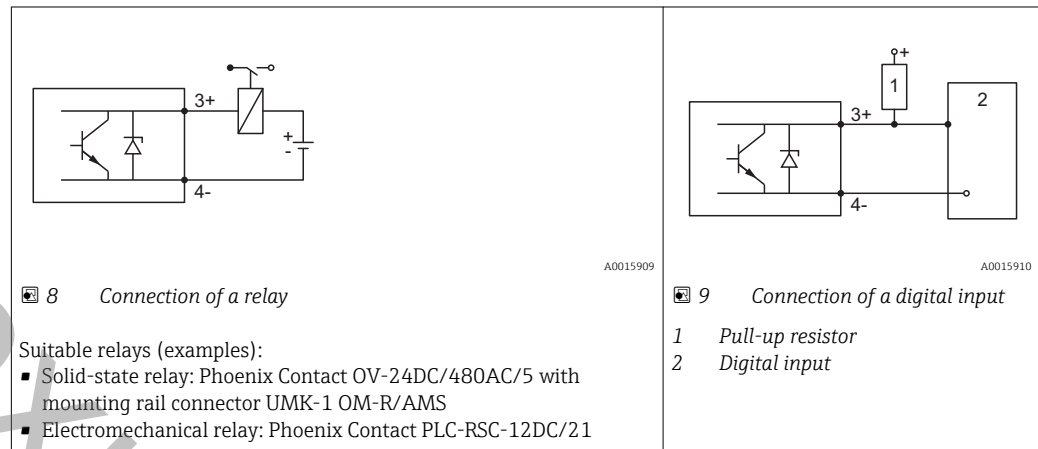

**i** For optimum interference immunity we recommend to connect an external resistor (internal resistance of the relay or Pull-up resistor) of  $< 1\,000\ \Omega$ .

**Device plug connectors**



For the versions with fieldbus plug connector (M12 or 7/8"), the signal line can be connected without opening the housing.

*Pin assignment of the M12 plug connector*

<p style="text-align: right; font-size: small;">A0011175</p>	Pin	Meaning
	1	Signal +
	2	not connected
	3	Signal -
	4	Ground

*Pin assignment of the 7/8" plug connector*

<p style="text-align: right; font-size: small;">A0011176</p>	Pin	Meaning
	1	Signal -
	2	Signal +
	3	Not connected
	4	Screen

ТЕХНОДИЗАЙН-М

## Supply voltage

An external power supply is required.



Various supply units can be ordered from Endress+Hauser: see "Accessories" section → 91

## 2-wire, 4-20mA HART, passive

"Power Supply, Output" <sup>1)</sup>	"Approval" <sup>2)</sup>	Terminal voltage U at the device	Maximum load R, depending on the supply voltage U <sub>0</sub> at the supply unit
A: 2-wire; 4-20mA HART	<ul style="list-style-type: none"> <li>■ Non-Ex</li> <li>■ Ex nA</li> <li>■ Ex ic</li> <li>■ CSA GP</li> </ul>	10.4 to 35 V <sup>3)</sup>	<p style="text-align: right; font-size: small;">A0017140</p>
	Ex ia / IS	10.4 to 30 V <sup>3)</sup>	
	<ul style="list-style-type: none"> <li>■ Ex d(ia) / XP</li> <li>■ Ex ic(ia)</li> <li>■ Ex nA(ia)</li> <li>■ Ex ta / DIP</li> </ul>	12 to 35 V <sup>4)</sup>	<p style="text-align: right; font-size: small;">A0019136</p>
Ex ia + Ex d(ia) / IS + XP	12 to 30 V <sup>4)</sup>		

1) Feature 020 of the product structure

2) Feature 010 of the product structure

3) For ambient temperatures  $T_a \leq -20^\circ\text{C}$  ( $-4^\circ\text{F}$ ) a minimum voltage of 15 V is required for the startup of the device at the MIN error current (3,6 mA). The startup current can be parametrized. If the device is operated with a fixed current  $I \geq 5,5$  mA (HART multidrop mode), a voltage of  $U \geq 10,4$  V is sufficient throughout the entire range of ambient temperatures.

4) For ambient temperatures  $T_a \leq -20^\circ\text{C}$  ( $-4^\circ\text{F}$ ) a minimum voltage of 16 V is required for the startup of the device at the MIN error current (3.6 mA).

"Power Supply, Output" <sup>1)</sup>	"Approval" <sup>2)</sup>	Terminal voltage U at the device	Maximum load R, depending on the supply voltage U <sub>0</sub> at the supply unit
B: 2-wire; 4-20 mA HART, switch output	<ul style="list-style-type: none"> <li>■ Non-Ex</li> <li>■ Ex nA</li> <li>■ Ex nA(ia)</li> <li>■ Ex ic</li> <li>■ Ex ic(ia)</li> <li>■ Ex d(ia) / XP</li> <li>■ Ex ta / DIP</li> <li>■ CSA GP</li> </ul>	12 to 35 V <sup>3)</sup>	<p style="text-align: right; font-size: small;">A0019136</p>
	<ul style="list-style-type: none"> <li>■ Ex ia / IS</li> <li>■ Ex ia + Ex d(ia) / IS + XP</li> </ul>	12 to 30 V <sup>3)</sup>	

1) Feature 020 of the product structure

2) Feature 010 of the product structure

3) For ambient temperatures  $T_a \leq -30^\circ\text{C}$  ( $-22^\circ\text{F}$ ) a minimum voltage of 16 V is required for the startup of the device at the MIN error current (3.6 mA).

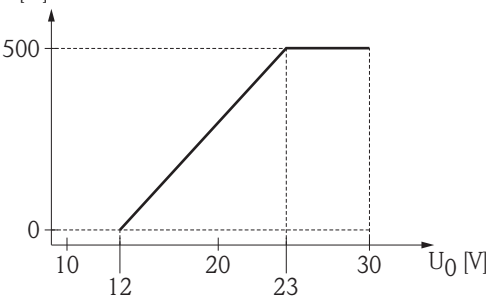

"Power Supply, Output" <sup>1)</sup>	"Approval" <sup>2)</sup>	Terminal voltage U at the device	Maximum load R, depending on the supply voltage U <sub>0</sub> at the supply unit
C: 2-wire; 4-20mA HART, 4-20mA	any	12 to 30 V <sup>3)</sup>	 <p>The graph plots Maximum load R [Ω] on the y-axis (0 to 500) against supply voltage U<sub>0</sub> [V] on the x-axis (10 to 30). The load is 0 Ω for U<sub>0</sub> &lt; 12 V. It increases linearly from 0 Ω at 12 V to 500 Ω at 23 V. From 23 V to 30 V, the load remains constant at 500 Ω.</p>

- 1) Feature 020 of the product structure
- 2) Feature 010 of the product structure
- 3) For ambient temperatures T<sub>a</sub> ≤ -30 °C (-22 °F) a minimum voltage of 16 V is required for the startup of the device at the MIN error current (3.6 mA).

<b>Polarity reversal protection</b>	Yes
<b>Admissible residual ripple at f = 0 to 100 Hz</b>	U <sub>SS</sub> < 1 V
<b>Admissible residual ripple at f = 100 to 10000 Hz</b>	U <sub>SS</sub> < 10 mV

**4-wire, 4-20mA HART, active**

"Power supply; Output" <sup>1)</sup>	Terminal voltage	Maximum load R <sub>max</sub>
<b>K:</b> 4-wire 90-253VAC; 4-20mA HART	90 to 253 V <sub>AC</sub> (50 to 60 Hz), overvoltage category II	500 Ω
<b>L:</b> 4-wire 10,4-48VDC; 4-20mA HART	10.4 to 48 V <sub>DC</sub>	

1) Feature 020 of the product structure

**PROFIBUS PA, FOUNDATION Fieldbus**

"Power supply; Output" <sup>1)</sup>	"Approval" <sup>2)</sup>	Terminal voltage
<b>E:</b> 2-wire; FOUNDATION Fieldbus, switch output <b>G:</b> 2-wire; PROFIBUS PA, switch output	<ul style="list-style-type: none"> <li>▪ Non-Ex</li> <li>▪ Ex nA</li> <li>▪ Ex nA(ia)</li> <li>▪ Ex ic</li> <li>▪ Ex ic(ia)</li> <li>▪ Ex d(ia) / XP</li> <li>▪ Ex ta / DIP</li> <li>▪ CSA GP</li> </ul>	9 to 32 V <sup>3)</sup>
	<ul style="list-style-type: none"> <li>▪ Ex ia / IS</li> <li>▪ Ex ia + Ex d(ia) / IS + XP</li> </ul>	9 to 30 V <sup>3)</sup>

1) Feature 020 of the product structure

2) Feature 010 of the product structure

3) Input voltages up to 35 V will not spoil the device.

<b>Polarity sensitive</b>	No
<b>FISCO/FNICO compliant according to IEC 60079-27</b>	Yes

**Power consumption**

"Power supply; Output" <sup>1)</sup>	Power consumption
<b>A:</b> 2-wire; 4-20mA HART	< 0.9 W
<b>B:</b> 2-wire; 4-20mA HART, switch output	< 0.9 W
<b>C:</b> 2-wire; 4-20mA HART, 4-20mA	< 2 x 0.7 W
<b>K:</b> 4-wire 90-253VAC; 4-20mA HART	6 VA
<b>L:</b> 4-wire 10,4-48VDC; 4-20mA HART	1.3 W

1) Feature 020 of the product structure

**Current consumption****HART**

<b>Nominal current</b>	3.6 to 22 mA, the start-up current for multidrop mode can be parametrized (is set to 3.6 mA on delivery)
<b>Breakdown signal (NAMUR NE43)</b>	adjustable: 3.59 to 22.5 mA

**PROFIBUS PA**

<b>Nominal current</b>	14 mA
<b>Error current FDE (Fault Disconnection Electronic)</b>	0 mA

## FOUNDATION Fieldbus

Device basic current	15 mA
Error current FDE (Fault Disconnection Electronic)	0 mA

## FISCO

$U_i$	17.5 V
$I_i$	550 mA
$P_i$	5.5 W
$C_i$	5 nF
$L_i$	10 $\mu$ H

- Power supply failure**
- Configuration is retained in the HistoROM (EEPROM).
  - Error messages (incl. value of operated hours counter) are stored.

- Potential equalization**
- No special measures for potential equalization are required.
-  If the device is designed for hazardous areas, observe the information in the documentation "Safety Instructions" (XA, ZD).

- Terminals**
- Without integrated overvoltage protection**  
Plug-in spring terminals for wire cross-sections 0.5 to 2.5 mm<sup>2</sup> (20 to 14 AWG)
  - With integrated overvoltage protection**  
Screw terminals for wire cross-sections 0.2 to 2.5 mm<sup>2</sup> (24 to 14 AWG)

- Cable entries**
- Connection of power supply and signal line**
- To be selected in feature 050 "Electrical connection"
- Gland M20; Material dependent on the approval:
    - For Non-Ex, ATEX, IECEx, NEPSI Ex ia/ic:  
Plastics M20x1.5 for cable  $\phi$  5 to 10 mm (0.2 to 0.39 in)
    - For Dust-Ex, FM IS, CSA IS, CSA GP, Ex nA:  
Metal M20x1.5 for cable  $\phi$  7 to 10 mm (0.28 to 0.39 in)<sup>1)</sup>
    - For Ex d:  
No gland available
  - Thread
    - $\frac{1}{2}$ " NPT
    - G  $\frac{1}{2}$ "
    - M20  $\times$  1.5
  - Plug M12 / Plug 7/8"  
Only available for Non-Ex, Ex ic, Ex ia

**Connection of remote display FHX50**

- Dependent on feature 030: "Display, Operation":
- "Prepared for display FHX50 + M12 connection":  
M12 socket
  - "Prepared for display FHX50 + custom connection":  
Thread M16

- Cable specification**
- Minimum cross-section: dependent on terminals  $\rightarrow$   27
  - For ambient temperature  $T_U \geq 60$  °C (140 °F): use cable for temperature  $T_U + 20$  K.

1) The material of the gland is dependent on the housing type; GT18 (stainless steel housing): 316L (1.4404); GT19 (plastic housing) and GT20 (aluminum housing): nickel-coated brass (CuZn).

**HART**

- A normal device cable suffices if only the analog signal is used.
- A shielded cable is recommended if using the HART protocol. Observe grounding concept of the plant.
- For 4-wire devices: Standard device cable is sufficient for the power line.

**PROFIBUS**

Use a twisted, screened two-wire cable, preferably cable type A.

-  For further information on the cable specifications, see Operating Instructions BA00034S "Guidelines for planning and commissioning PROFIBUS DP/PA", PNO Guideline 2.092 "PROFIBUS PA User and Installation Guideline" and IEC61158-2 (MBP).

**FOUNDATION Fieldbus**

Endress+Hauser recommends using twisted, shielded two-wire cables.

-  For further information on the cable specifications, see Operating Instructions BA00013S "FOUNDATION Fieldbus Overview", FOUNDATION Fieldbus Guideline and IEC 61158-2 (MBP).

**Overvoltage protection**

If the measuring device is used for level measurement in flammable liquids which requires the use of overvoltage protection according to DIN EN 60079-14, standard for test procedures 60060-1 (10 kA, pulse 8/20  $\mu$ s), overvoltage protection has to be ensured by an integrated or external overvoltage protection module.

**Integrated overvoltage protection**

An integrated overvoltage protection module is available for 2-wire HART as well as PROFIBUS PA and FOUNDATION Fieldbus devices.

Product structure: Feature 610 "Accessory mounted", option NA "Overvoltage protection".

Technical data	
Resistance per channel	2 * 0.5 $\Omega$ max
Threshold DC voltage	400 to 700 V
Threshold impulse voltage	< 800 V
Capacitance at 1 MHz	< 1.5 pF
Nominal arrest impulse voltage (8/20 $\mu$ s)	10 kA

**External overvoltage protection**

HAW562 or HAW569 from Endress+Hauser are suited as external overvoltage protection.

-  For detailed information please refer to the following documents:
- HAW562: TI01012K
  - HAW569: TI01013K

## Performance characteristics

**Reference operating conditions**

- Temperature = +24 °C (+75 °F) ±5 °C (±9 °F)
- Pressure = 960 mbar abs. (14 psia) ±100 mbar (±1.45 psi)
- Humidity = 60 % ±15 %
- Reflector: metal plate with a minimum diameter of 1 m (40 in)
- No major interference reflections inside the signal beam

**Maximum measured error**

Typical data under reference operating conditions: DIN EN 61298-2, percentage values in relation to the span.

Device	Value	Output	
		digital	analog <sup>1)</sup>
FMR56/FMR57	Sum of non-linearity, nonrepeatability and hysteresis	± 3 mm (0.12 in)	± 0.02 %
	Offset/Zero	± 4 mm (0.2 in)	± 0.03 %

1) Only relevant for 4-20mA current output; add error of the analog value to the digital value.

**Differing values in near-range applications**

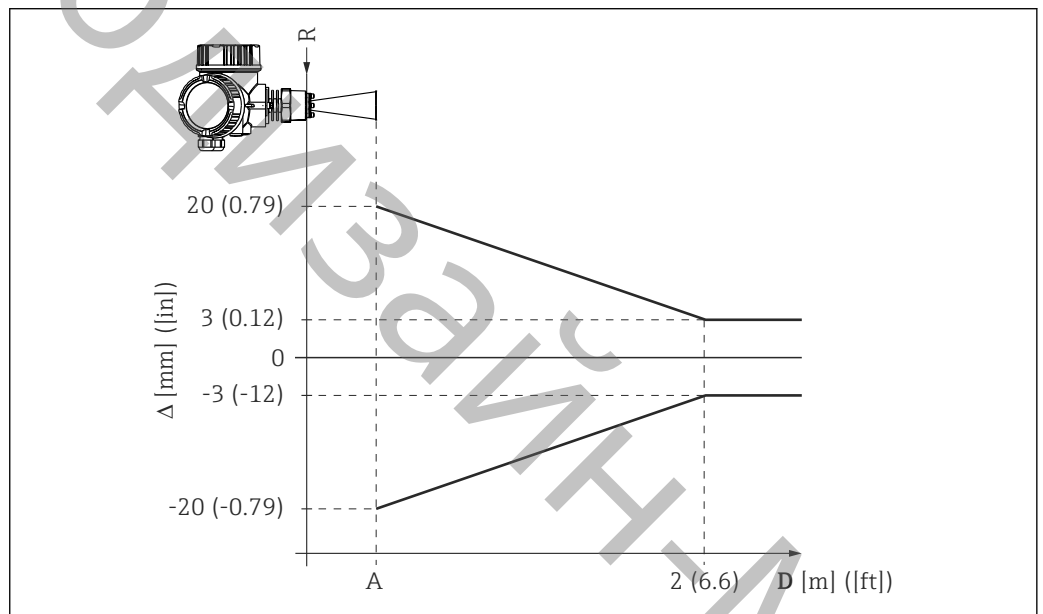

10 Maximum measured error in near-range applications

- Δ Maximum measured error
- A Lower edge of the antenna
- D Distance from the lower edge A of the antenna
- R Reference point of the distance measurement

**Measured value resolution**

Dead band according to EN61298-2:

- digital: 1 mm
- analog: 1 μA

**Reaction time**

The reaction time can be parametrized. The following step response times (as per DIN EN 61298-2)<sup>2)</sup> are valid if the damping is switched off:

Tank height	Sampling rate	Step response time
< 10 m (33 ft)	$\geq 3.6 \text{ s}^{-1}$	< 0.8 s
< 70 m (230 ft)	$\geq 2.2 \text{ s}^{-1}$	< 1 s

**Influence of ambient temperature**

**The measurements are carried out in accordance with EN 61298-3**

- Digital (HART, PROFIBUS PA, FOUNDATION Fieldbus): average  $T_K = 5 \text{ mm}/10 \text{ K}$ ; maximum 15 mm
- Analog (current output):
  - zero point (4 mA): average  $T_K = 0.02 \text{ %}/10 \text{ K}$
  - span (20 mA): average  $T_K = 0.05 \text{ %}/10 \text{ K}$

2) According to DIN EN 61298-2 the response time is the time which passes after a sudden change of the input signal until the output signal for the first time assumes 90% of the steady-state value.

## Installation

### Installation conditions

### Mounting position

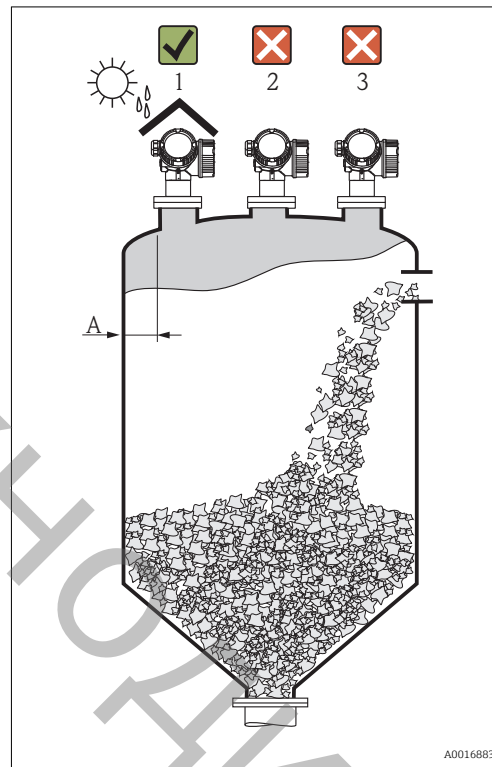

- Recommended distance **A** from wall to outer edge of nozzle:  $\sim 1/6$  of vessel diameter. Nevertheless the device should not be installed closer than 20 cm (7.87 in) to the vessel wall.  
If the wall of the vessel is not smooth (corrugated metal, welding seams, irregularities etc.) the distance from the wall should be kept as large as possible. If necessary, use an alignment device to prevent interference reflections from the wall → 41.
- Not in the center (2), as interference can cause signal loss.
- Not above the fill stream (3).
- It is recommended to use a weather protection cover (1) in order to protect the device from direct sun or rain.
- In extremely dusty applications, the integrated air purge connection can prevent clogging of the antenna → 41.

## Vessel installations

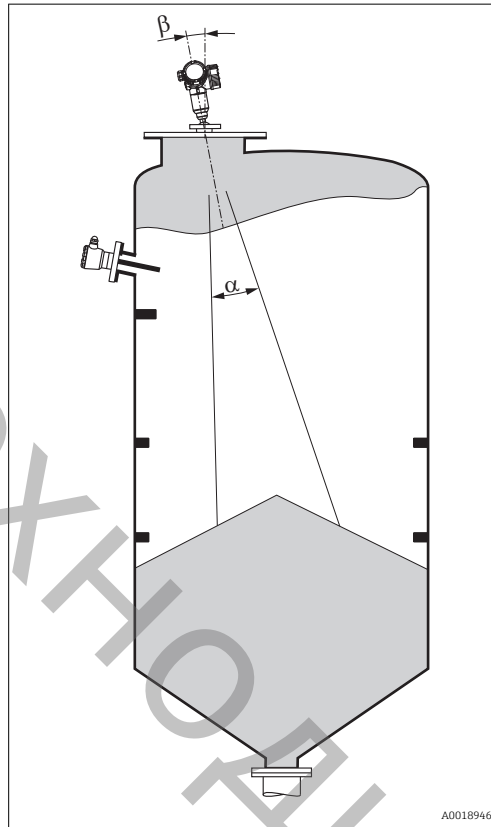

Avoid any installations (limit switches, temperature sensors, braces etc.) inside the signal beam. Take into account the beam angle → 34.

## Reduction of interference echoes

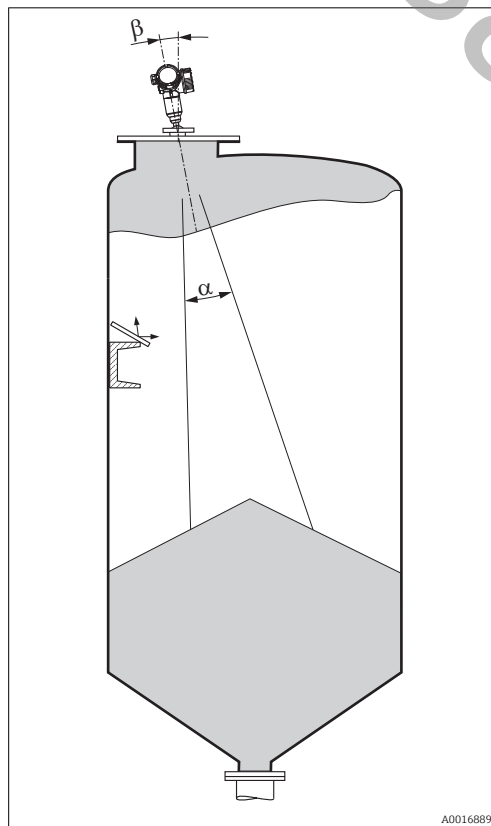

Metallic screens mounted at a slope spread the radar signal and can, therefore, reduce interference echoes.



### Measurement in a plastic vessel

If the outer wall of the vessel is made of a non-conductive material (e.g. GRP), microwaves can also be reflected off interfering installations outside the signal beam (e.g. metallic pipes (1), ladders (2), grates (3), ...). Therefore, there should be no such interfering installations in the signal beam. Please contact Endress+Hauser for further information.

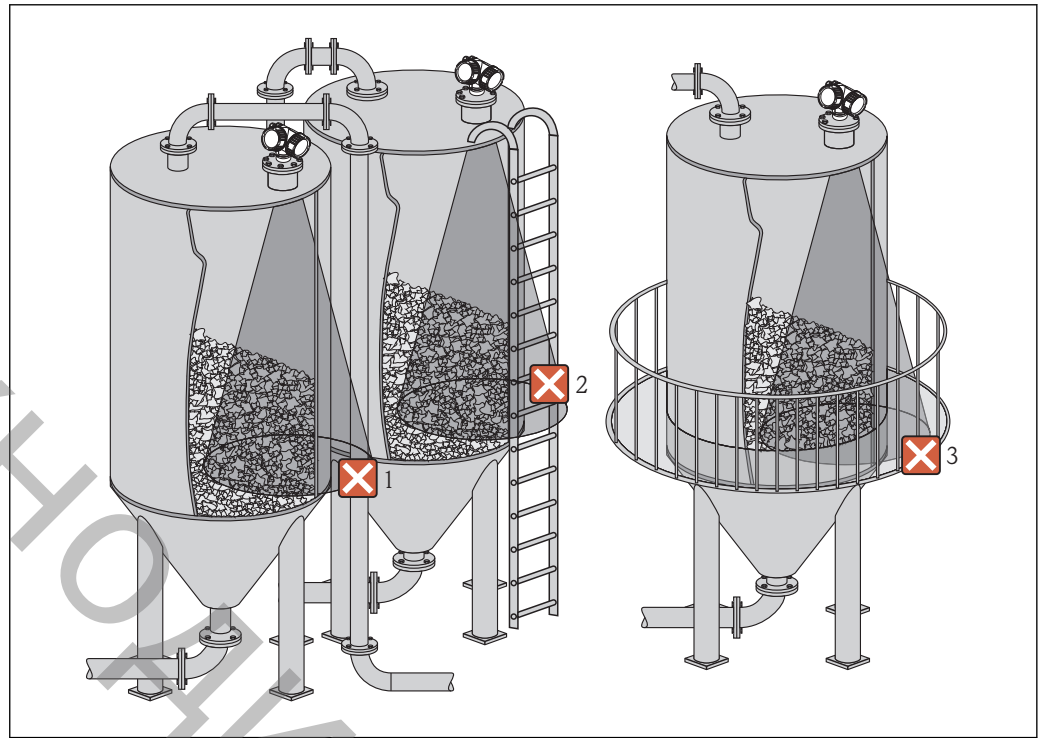

A0017125

### Optimization options

- Antenna size  
The bigger the antenna, the smaller the beam angle  $\alpha$  and the fewer interference echoes  
→ 34.
- Mapping  
The measurement can be optimized by means of electronic suppression of interference echoes.
- Antenna alignment  
Take into account the marker on the flange or threaded connection → 36.
- Metallic screens mounted at a slope  
They spread the radar signals and can, therefore, reduce interference echoes.
- Variable flange seal (FMR56)  
Using the variable flange seal, the device can be aligned in the direction of the product surface. For details refer to Operating Instructions BA01048F, chapter "Accessories".
- Alignment device for FMR57  
In FMR57 with alignment device, the sensor can be optimally aimed within the vessel and thus interference echoes can be avoided. The maximum angle  $\beta$  is  $\pm 15^\circ$ .  
In particular, sensor alignment serves to:
  - prevent interference reflections
  - extend the maximum possible measuring range in conical outlets

**Beam angle**

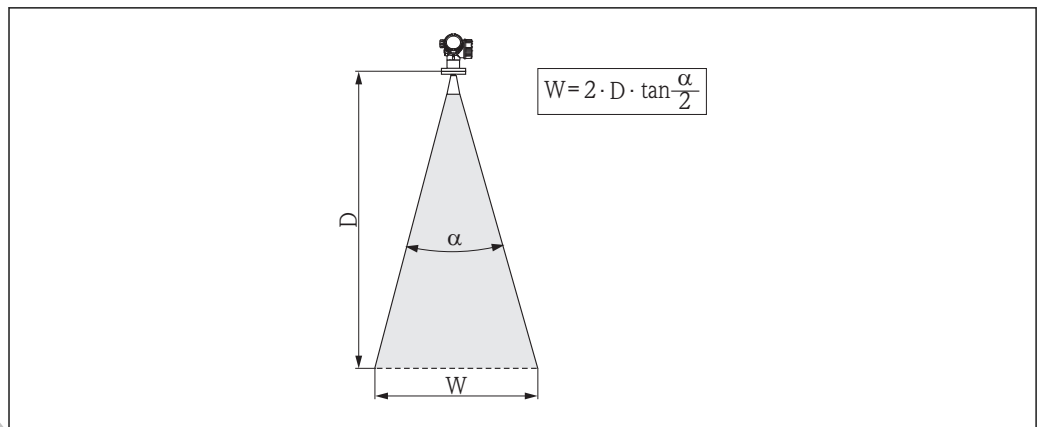

A0016891

11 Relationship between beam angle  $\alpha$ , distance  $D$  and beamwidth diameter  $W$

The beam angle is defined as the angle  $\alpha$  where the energy density of the radar waves reaches half the value of the maximum energy density (3-dB-width). Microwaves are also emitted outside the signal beam and can be reflected off interfering installations.

Beam diameter  $W$  as a function of beam angle  $\alpha$  and measuring distance  $D$ :

FMR56		
Antenna size	80 mm (3 in)	100 mm (4 in)
Beam angle $\alpha$	10°	8°
Measuring distance (D)	Beamwidth diameter (W)	
3 m (9.8 ft)	0.53 m (1.7 ft)	0.42 m (1.4 ft)
6 m (20 ft)	1.05 m (3.4 ft)	0.84 m (2.8 ft)
9 m (30 ft)	1.58 m (5.2 ft)	1.26 m (4.1 ft)
12 m (39 ft)	2.1 m (6.9 ft)	1.68 m (5.5 ft)
15 m (49 ft)	2.63 m (8.6 ft)	2.10 m (6.9 ft)
20 m (66 ft)	3.50 m (11 ft)	2.80 m (9.2 ft)
25 m (82 ft)	4.37 m (14 ft)	3.50 m (11 ft)
30 m (98 ft)	5.25 m (17 ft)	4.20 m (14 ft)

FMR57 - Horn antenna		
Antenna size	80 mm (3 in)	100 mm (4 in)
Beam angle $\alpha$	10°	8°
Measuring distance (D)	Beamwidth diameter W	
5 m (16 ft)	0.87 m (2.9 ft)	0.7 m (2.3 ft)
10 m (33 ft)	1.75 m (5.7 ft)	1.4 m (4.6 ft)
15 m (49 ft)	2.62 m (8.6 ft)	2.1 m (6.9 ft)
20 m (66 ft)	3.50 m (11 ft)	2.80 m (9.2 ft)
30 m (98 ft)	5.25 m (17 ft)	4.20 m (14 ft)
40 m (131 ft)	7.00 m (23 ft)	5.59 m (18 ft)
50 m (164 ft)	8.75 m (29 ft)	6.99 m (23 ft)

FMR57 - Parabolic antenna		
Antenna size	200 mm (8 in)	250 mm (10 in)
Beam angle $\alpha$	4°	3,5°
Measuring distance (D)	Beamwidth diameter W	
5 m (16 ft)	0.35 m (1.1 ft)	0.30 m (1 ft)
10 m (33 ft)	0.70 m (2.3 ft)	0.61 m (2 ft)
15 m (49 ft)	1.05 m (3.4 ft)	0.92 m (3 ft)
20 m (66 ft)	1.40 m (4.6 ft)	1.22 m (4 ft)
30 m (98 ft)	2.10 m (6.9 ft)	1.83 m (6 ft)
40 m (131 ft)	2.79 m (9.2 ft)	2.44 m (8 ft)
50 m (164 ft)	3.50 m (11 ft)	3.06 m (10 ft)
60 m (197 ft)	4.19 m (14 ft)	3.70 m (12 ft)
70 m (230 ft)	4.90 m (16 ft)	4.28 m (14 ft)

**Measuring conditions**

- The measuring range begins, where the beam hits the bottom. Particularly with conical outlets the level cannot be detected below this point. The maximum measuring range can be increased in such applications by using an alignment device → 41.
- In case of media with a low dielectric constant ( $\epsilon_r = 1.5$  to  $2.5$ )<sup>3)</sup>, the bottom can be visible through the medium at low levels. In order to guarantee the required accuracy in these cases, it is recommended to position the zero-point at a distance **C** above the bottom (see figure).
- In principle it is possible to measure up to the tip of the antenna with Micropilot. However, due to considerations regarding abrasion and build-up and depending on the orientation of the product surface (angle of repose), the end of the measuring range should be at a distance of **A** (see figure) from the tip of the antenna. If required, and if some conditions (high DC value, flat angle of repose) are met, shorter distances can be achieved.

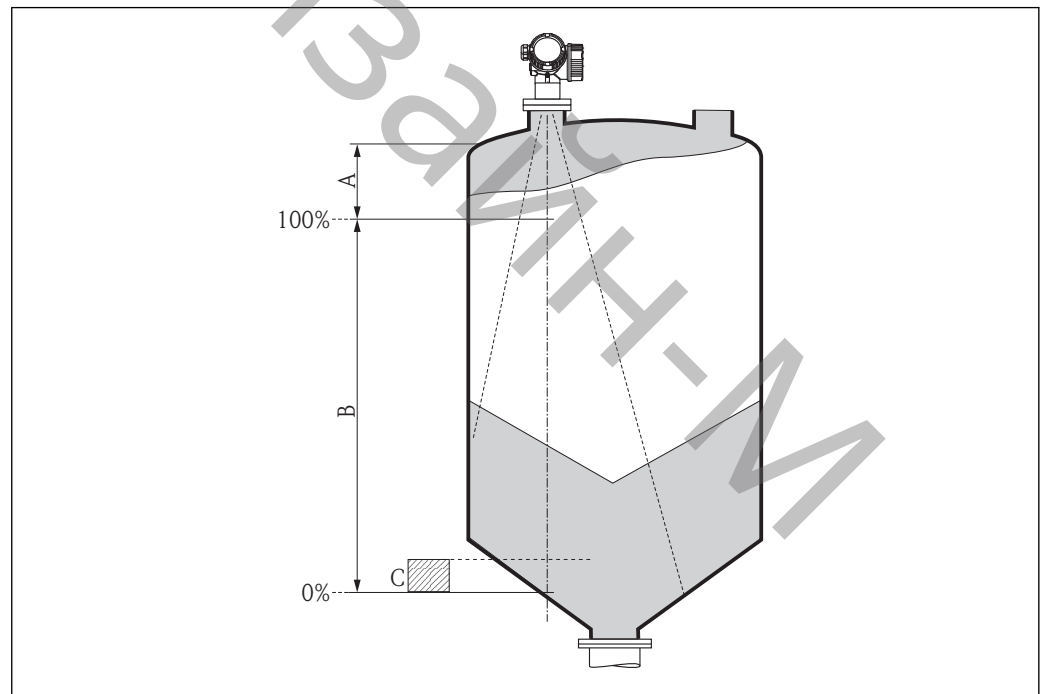

A0016916

3) Dielectric constants of important media commonly used in various industries are summarized in the DC manual (CP01076F) and in the Endress +Hauser "DC Values App" (available for Android and iOS).

Device	A [mm (in)]	C [mm (in)]
FMR56	400(15.7)	50 to 150(1.97 to 5.91)
FMR57		

### Installation in vessel (free space)

#### Horn antenna with slip-on flange (FMR56)

##### Alignment

**i** When using the Micropilot with a slip-on flange in explosion-hazardous areas, strictly observe all specifications in the relevant Safety Instructions (XA).

- Align the antenna vertically to the product surface.  
Optionally, a variable flange seal, which is available as an accessory, can be used for alignment (see Technical Information BA01048F, chapter "Accessories").
- A marking at the boss enables alignment of the antenna. This marking must be aligned towards the tank wall as well as possible.

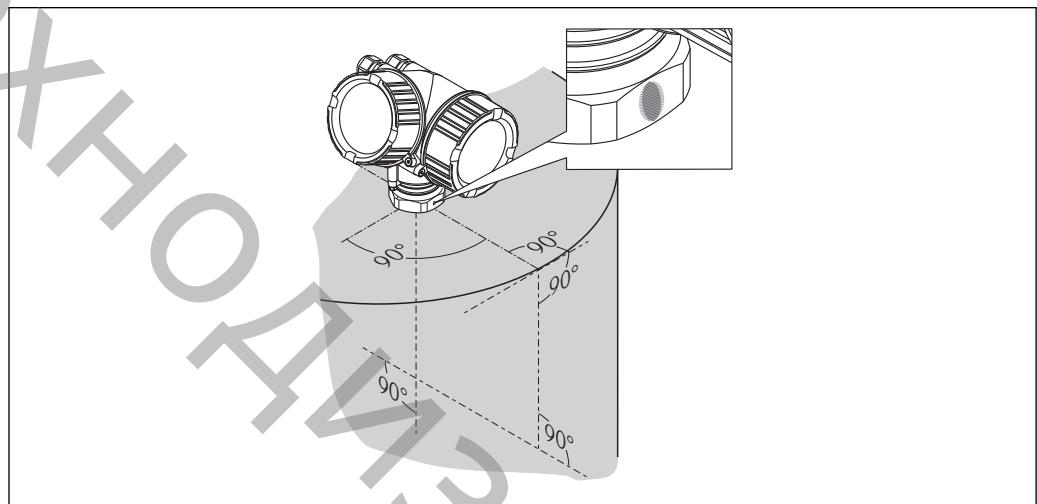

A0019434

**i** Depending on the device version the marking may be a circle or two short parallel lines.

##### Nozzle mounting

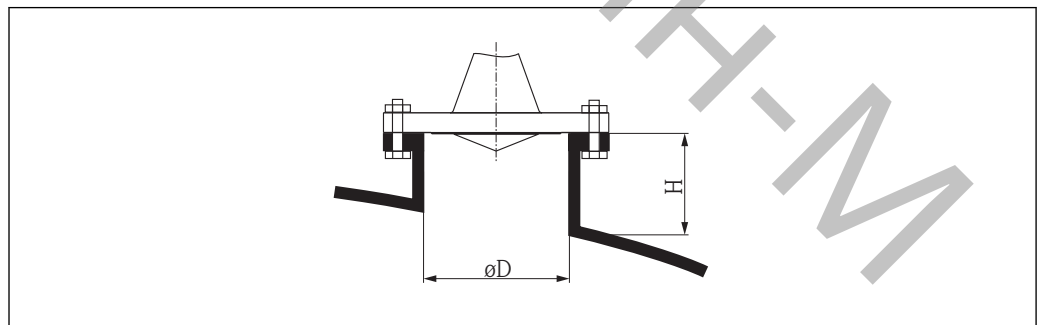

A0016868

**12** Nozzle height and diameter for horn antenna with slip-on flange

Nozzle diameter $D$	Maximum nozzle height $H_{max}$
80 mm (3 in)	300 mm (11.8 in)
100 mm (4 in)	400 mm (15.8 in)
150 mm (6 in)	500 mm (19.7 in)

### Horn antenna with mounting bracket (FMR56)

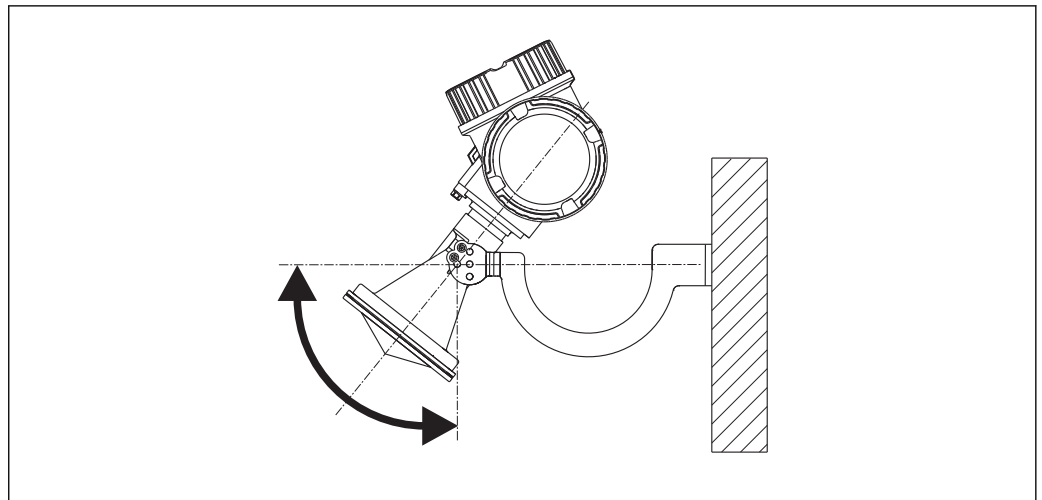

A0016865

13 Installation of the horn antenna with mounting bracket

Align the antenna vertically to the product surface using the mounting bracket.

#### NOTICE

**The mounting bracket has no conductive connection to the transmitter housing.**

Danger of electrostatic charge

- ▶ Connect the mounting bracket to the local potential equalization system.

### Horn antenna (FMR57)

#### Alignment

- Ideally, the horn antenna should be installed vertically. To avoid interference reflections or for optimum alignment within the vessel, the Micropilot with optional alignment device can be inclined by 15° in all directions → 41.
- A marking at the boss enables alignment of the antenna. This marking must be aligned towards the tank wall as well as possible.

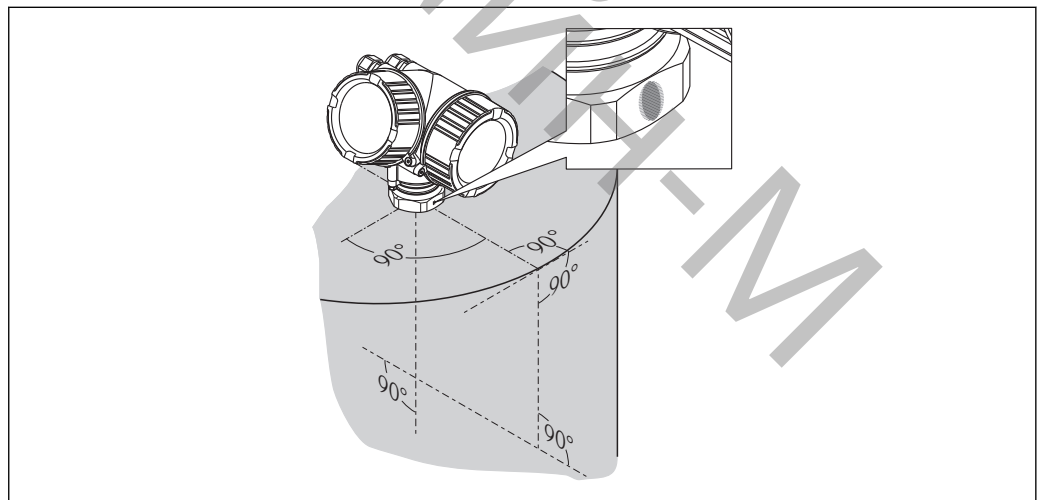

A0019434



Depending on the device version the marking may be a circle or two short parallel lines.

#### Nozzle mounting

The horn antenna should protrude from the nozzle. If this is not possible for mechanical reasons, larger nozzle heights can be accepted.

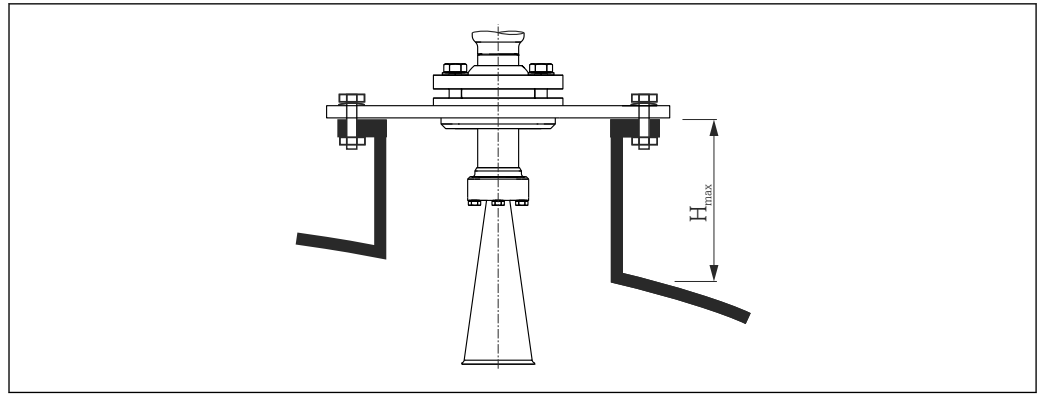

A0016825

14 Nozzle height for the horn antenna (FMR57)

Antenna <sup>1)</sup>	Maximum nozzle height $H_{max}$ <sup>2)</sup>
BC: Horn 80mm/3"	260 mm (10.2 in)
BD: Horn 100mm/4"	480 mm (18.9 in)

- 1) Feature 070 of the product structure  
 2) valid for antennas without antenna extension

**i** Please contact Endress+Hauser for applications with higher nozzle.

#### Threaded connection

**i** For devices with a threaded connection it may be necessary - depending on the antenna size - to unmount the horn before fastening the device and to mount it again afterwards.

- Tighten with the hexagonal nut only.
- Tool : 60 mm hexagonal wrench
- Maximum permissible torque: 60 Nm (44 lbf ft)

#### Parabolic antenna (FMR57)

##### Alignment

Ideally, the parabolic antenna should be installed vertically. To avoid interference reflections or for optimum alignment within the vessel, the Micropilot with optional alignment device can be swiveled by 15° in all directions → 41.

##### Nozzle mounting

- Case 1: Ideally, the parabolic antenna should protrude from the nozzle (1). Particularly when using the alignment device, please ensure that the parabolic reflector is protruding from the nozzle/roof so as not to inhibit alignment.
- Case 2: For applications with higher nozzle it may be necessary to install the parabolic antenna completely in the nozzle (2).  
 The maximum height of the nozzle ( $H_{max}$ ) to the parabolic mirror should not exceed 500 mm (19.7 in). Interfering edges within the nozzle should be avoided.

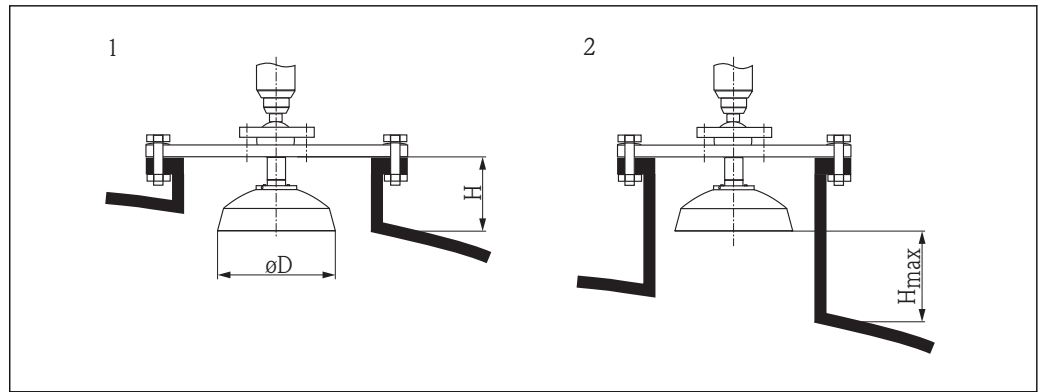

A0016827

15 Nozzle mounting of Micropilot FMR57 with parabolic antenna

- 1 Antenna protrudes from the nozzle
- 2 Antenna completely within the nozzle

Antenn <sup>1)</sup>	Antenna diameter $D$	Nozzle height $H$ for case 1	Maximum nozzle height $H_{max}$ for case 2
FA: Parabol 200mm/8"	173 mm (6.81 in)	< 50 mm (1.97 in)	500 mm (19.7 in)
FB: Parabol 250mm/10"	236 mm (9.29 in)	< 50 mm (1.97 in)	500 mm (19.7 in)

1) Feature 070 of the product structure

*Examples for installation with small flange*

If the flange is smaller than the parabolic reflector, the device can be mounted in one of the following ways:

- Standard installation → 39  
This requires dismantling of the parabolic reflector.
- Installation with hinged flange → 40

*Standard installation*

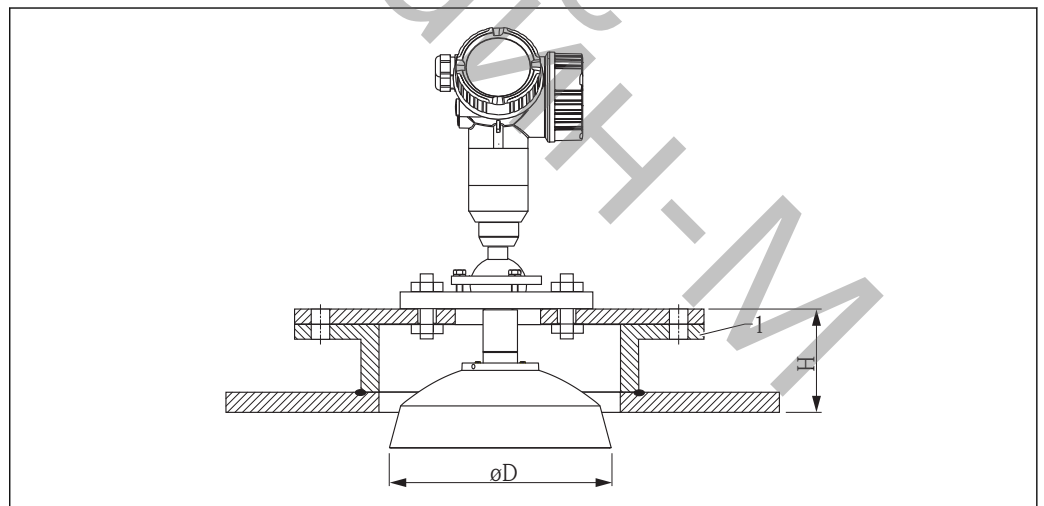

A0018874

1 Nozzle

Antenna size	$\phi D$	H <sup>1)</sup>
200 mm (8 in)	173 mm (6.81 in)	< 50 mm (1.96 in)
250 mm (10 in)	236 mm (9.29 in)	< 50 mm (1.96 in)

1) without antenna extension

#### Installation with hinged flange

 At hinged flanges, the length of the antenna must be taken into account.

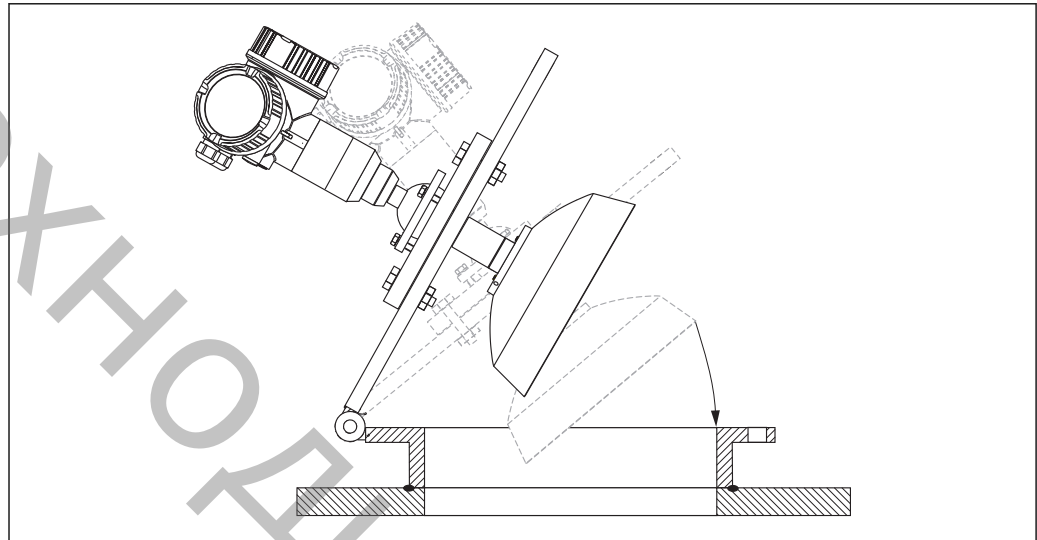

A0018878

#### Dismantling the parabolic reflector

For installation in a nozzle, the parabolic reflector can be dismantled:



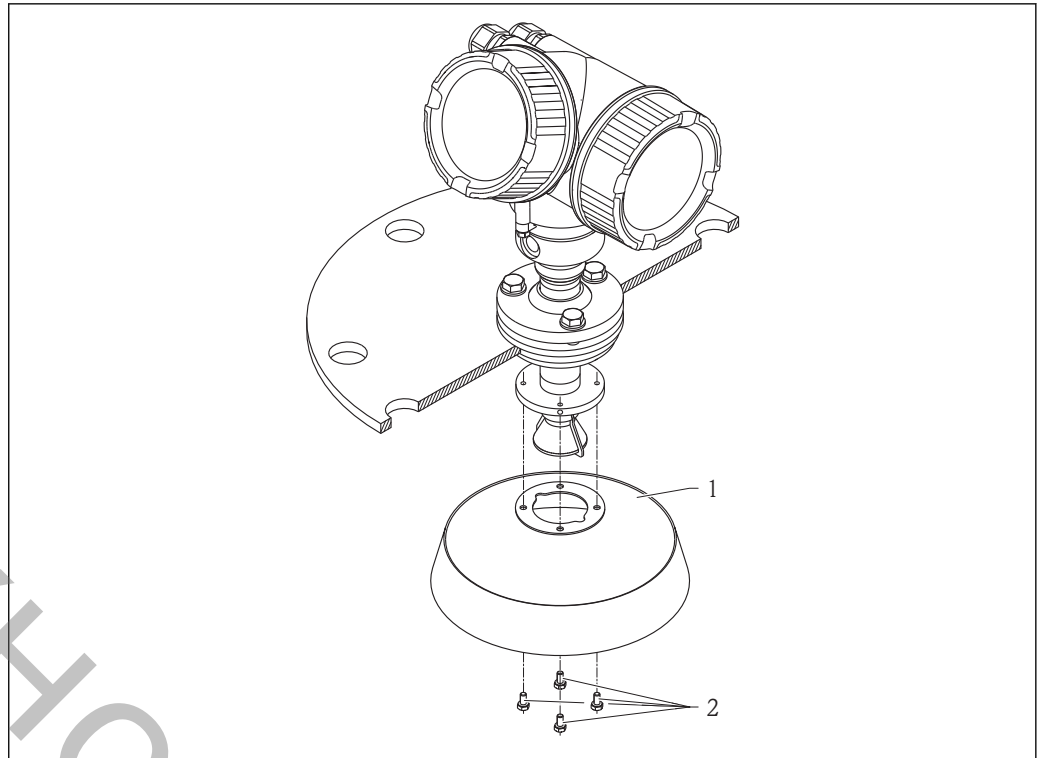

A0018877

- 1 Parabolic reflector
- 2 4 bolts; torque: 3 Nm (2,2 lbf ft)

#### Alignment device for FMR57

Using the alignment device it is possible to tilt the antenna axis by up to 15° in all directions. The alignment device is used for the optimum alignment of the radar beam with the bulk solids surface.

Product structure: Feature 100 "Process connection", options XCJ, XEJ, XFJ

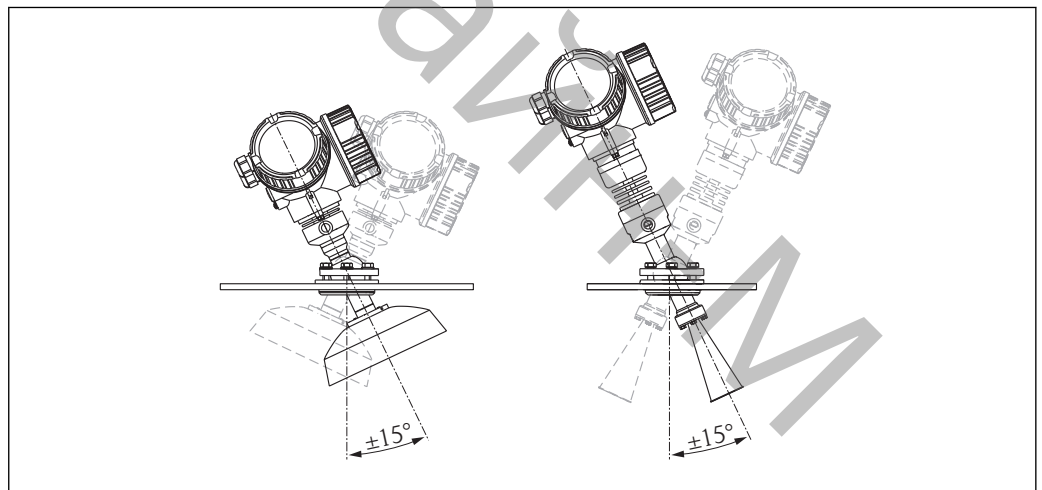

A0016931

16 Micropilot FMR57 with alignment device

#### Integrated air purge connection for FMR57

In extremely dusty applications, the integrated air purge connection can prevent clogging of the antenna. Pulsed operation is recommended.

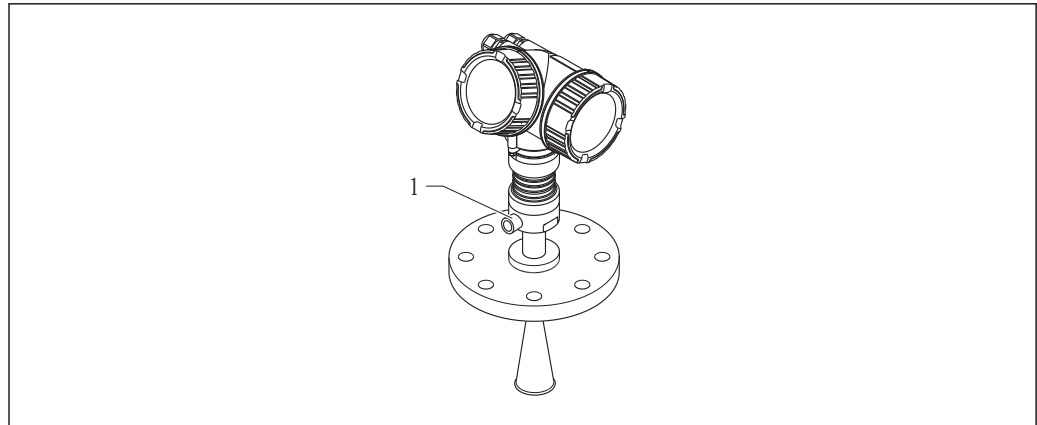

A0016932

17 Micropilot FMR57 with air purge connection

1 Air purge connection NPT $\frac{1}{4}$  or G $\frac{1}{4}$

**Pressure range of the purge air**

- **Pulsed operation:**  
max. 6 bar (87 psi)
- **Permanent operation:**  
200 to 500 mbar (3 to 7.25 psi)

**i** Make sure to use dry purge air.

**i** In general, air purging should only be used as much as necessary, since too much air purging may cause mechanical damage (abrasion).

**Vessels with heat insulation**

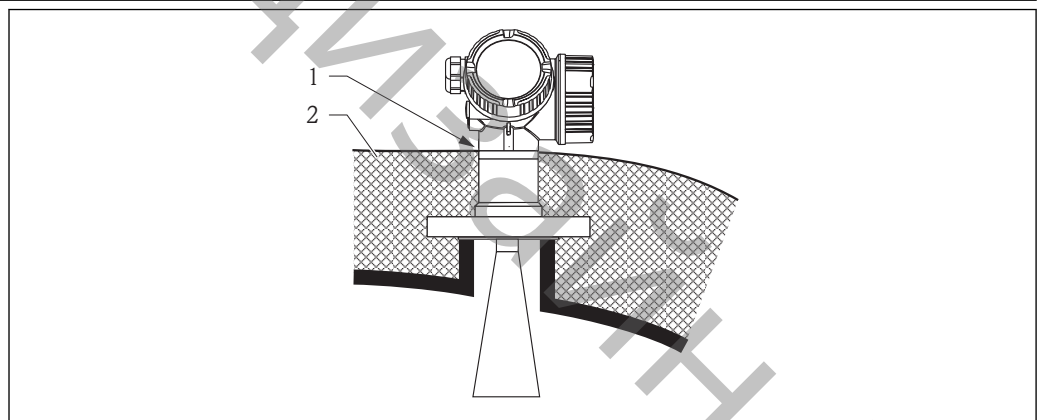

A0019142

If process temperatures are high, the device must be included in normal tank insulation to prevent the electronics heating up as a result of heat radiation or convection. The insulation may not exceed beyond the neck of the housing.

## Environment

<b>Ambient temperature range</b>	<b>Measuring device</b>	-40 to +80 °C (-40 to +176 °F); -50 °C (-58 °F) with manufacturer declaration on request
	<b>Local display</b>	-20 to +70 °C (-4 to +158 °F), the readability of the display may be impaired at temperatures outside the temperature range.

When operating the device in the open with strong sunlight:

- Mount the device in a shady position.
- Avoid direct sunlight, especially in warmer regions.
- Use a weather protection cover (see accessories).

**Ambient temperature limits**  The following diagrams take into account only functional aspects. There may be further restrictions for certified device versions. Please refer to the separate Safety Instructions → 92.

With a temperature ( $T_p$ ) at the process connection the admissible ambient temperature ( $T_a$ ) is reduced according to the following diagram (temperature derating):

Information concerning the derating tables

Option	Meaning
A	2-wire; 4-20 mA HART
B	2-wire; 4-20 mA HART, switch output
C	2-wire; 4-20 mA HART, 4-20 mA
E	2-wire; FF, switch output
G	2-wire; PA, switch output
K	4-wire 90-253VAC; 4-20 mA HART
L	4-wire 10, 4-48VDC; 4-20 mA HART

Power Supply; Output (Pos. 2 of the product structure)	P1		P2		P3		P4		P5		P6	
	$T_p$	$T_a$	$T_p$	$T_a$	$T_p$	$T_a$	$T_p$	$T_a$	$T_p$	$T_a$	$T_p$	$T_a$
A	-40 (-40)	80 (176)	80 (176)	80 (176)	80 (176)	80 (176)	80 (176)	-40 (-40)	-40 (-40)	-40 (-40)	-	-
B Switch output not used	-40 (-40)	76 (169)	76 (169)	76 (169)	80 (176)	75 (167)	80 (176)	-40 (-40)	-40 (-40)	-40 (-40)	-	-
B Switch output used	-40 (-40)	60 (140)	60 (140)	60 (140)	80 (176)	58 (136)	80 (176)	-40 (-40)	-40 (-40)	-40 (-40)	-	-
C Channel 2 not used	-40 (-40)	80 (176)	80 (176)	80 (176)	80 (176)	80 (176)	80 (176)	-40 (-40)	-40 (-40)	-40 (-40)	-	-
C Channel 2 used	-40 (-40)	74 (165)	74 (165)	74 (165)	80 (176)	73 (163)	80 (176)	-40 (-40)	-40 (-40)	-40 (-40)	-	-
E, G Switch output not used	-40 (-40)	79 (174)	79 (174)	79 (174)	80 (176)	79 (174)	80 (176)	-40 (-40)	-40 (-40)	-40 (-40)	-	-
E, G Switch output used	-40 (-40)	63 (145)	63 (145)	63 (145)	80 (176)	60 (140)	80 (176)	-40 (-40)	-40 (-40)	-40 (-40)	-	-

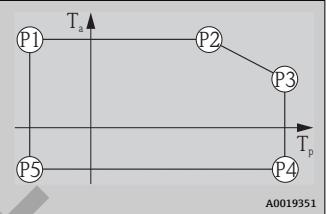

**FMR56**  
Housing: GT20 (Alu, coated)  
Temperature unit: °C (°F)

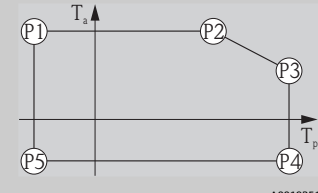

Power Supply; Output (Pos. 2 of the product structure)	P1		P2		P3		P4		P5		P6	
	T <sub>p</sub>	T <sub>a</sub>	T <sub>p</sub>	T <sub>a</sub>	T <sub>p</sub>	T <sub>a</sub>	T <sub>p</sub>	T <sub>a</sub>	T <sub>p</sub>	T <sub>a</sub>	T <sub>p</sub>	T <sub>a</sub>
A	-40 (-40)	80 (176)	80 (176)	80 (176)	80 (176)	80 (176)	80 (176)	-40 (-40)	-40 (-40)	-40 (-40)	-	-
B Switch output not used	-40 (-40)	80 (176)	80 (176)	80 (176)	80 (176)	80 (176)	80 (176)	-40 (-40)	-40 (-40)	-40 (-40)	-	-
B Switch output used	-40 (-40)	77 (171)	77 (171)	77 (171)	80 (176)	76 (169)	80 (176)	-40 (-40)	-40 (-40)	-40 (-40)	-	-
C Channel 2 not used	-40 (-40)	80 (176)	80 (176)	80 (176)	80 (176)	80 (176)	80 (176)	-40 (-40)	-40 (-40)	-40 (-40)	-	-
C Channel 2 used	-40 (-40)	79 (174)	79 (174)	79 (174)	80 (176)	79 (174)	80 (176)	-40 (-40)	-40 (-40)	-40 (-40)	-	-
E, G Switch output not used	-40 (-40)	80 (176)	80 (176)	80 (176)	80 (176)	80 (176)	80 (176)	-40 (-40)	-40 (-40)	-40 (-40)	-	-
E, G Switch output used	-40 (-40)	78 (172)	78 (172)	78 (172)	80 (176)	78 (172)	80 (176)	-40 (-40)	-40 (-40)	-40 (-40)	-	-
K, L	-40 (-40)	77 (171)	77 (171)	77 (171)	80 (176)	77 (171)	80 (176)	-40 (-40)	-40 (-40)	-40 (-40)	-	-

**FMR57**  
Seal: Viton GLT  
Housing: GT18 (316 L)  
Temperature unit: °C (°F)

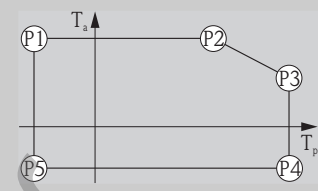

Power Supply; Output (Pos. 2 of the product structure)	P1		P2		P3		P4		P5		P6	
	T <sub>p</sub>	T <sub>a</sub>	T <sub>p</sub>	T <sub>a</sub>	T <sub>p</sub>	T <sub>a</sub>	T <sub>p</sub>	T <sub>a</sub>	T <sub>p</sub>	T <sub>a</sub>	T <sub>p</sub>	T <sub>a</sub>
A	-40 (-40)	81 (178)	81 (178)	81 (178)	200 (392)	67 (153)	200 (392)	-40 (-40)	-40 (-40)	-40 (-40)	-	-
B Switch output not used	-40 (-40)	82 (180)	82 (180)	82 (180)	200 (392)	67 (153)	200 (392)	-40 (-40)	-40 (-40)	-40 (-40)	-	-
B Switch output used	-40 (-40)	77 (171)	77 (171)	77 (171)	200 (392)	62 (144)	200 (392)	-40 (-40)	-40 (-40)	-40 (-40)	-	-
C Channel 2 not used	-40 (-40)	82 (180)	82 (180)	82 (180)	200 (392)	68 (154)	200 (392)	-40 (-40)	-40 (-40)	-40 (-40)	-	-
C Channel 2 used	-40 (-40)	79 (174)	79 (174)	79 (174)	200 (392)	64 (147)	200 (392)	-40 (-40)	-40 (-40)	-40 (-40)	-	-
E, G Switch output not used	-40 (-40)	83 (181)	83 (181)	83 (181)	200 (392)	68 (154)	200 (392)	-40 (-40)	-40 (-40)	-40 (-40)	-	-
E, G Switch output used	-40 (-40)	78 (172)	78 (172)	78 (172)	200 (392)	63 (145)	200 (392)	-40 (-40)	-40 (-40)	-40 (-40)	-	-
K, L	-40 (-40)	77 (171)	77 (171)	77 (171)	200 (392)	62 (144)	200 (392)	-40 (-40)	-40 (-40)	-40 (-40)	-	-

**FMR57**  
 Seal: Viton GLT  
 Housing: GT19 (Plastics PBT)  
 Temperature unit: °C (°F)

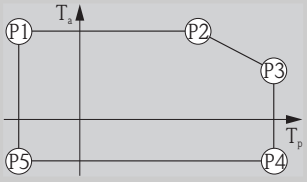

Power Supply; Output (Pos. 2 of the product structure)	P1		P2		P3		P4		P5		P6	
	T <sub>p</sub>	T <sub>a</sub>	T <sub>p</sub>	T <sub>a</sub>	T <sub>p</sub>	T <sub>a</sub>	T <sub>p</sub>	T <sub>a</sub>	T <sub>p</sub>	T <sub>a</sub>	T <sub>p</sub>	T <sub>a</sub>
A	-40 (-40)	80 (176)	80 (176)	80 (176)	200 (392)	53 (127)	200 (392)	-40 (-40)	-40 (-40)	-40 (-40)	-	-
B Switch output not used	-40 (-40)	76 (169)	76 (169)	76 (169)	200 (392)	53 (127)	200 (392)	-40 (-40)	-40 (-40)	-40 (-40)	-	-
B Switch output used	-40 (-40)	60 (140)	60 (140)	60 (140)	200 (392)	37 (99)	200 (392)	-40 (-40)	-40 (-40)	-40 (-40)	-	-
C Channel 2 not used	-40 (-40)	82 (180)	82 (180)	82 (180)	200 (392)	53 (127)	200 (392)	-40 (-40)	-40 (-40)	-40 (-40)	-	-
C Channel 2 used	-40 (-40)	74 (165)	74 (165)	74 (165)	200 (392)	53 (127)	200 (392)	-40 (-40)	-40 (-40)	-40 (-40)	-	-
E, G Switch output not used)	-40 (-40)	79 (174)	79 (174)	79 (174)	200 (392)	53 (127)	200 (392)	-40 (-40)	-40 (-40)	-40 (-40)	-	-
E, G Switch output used	-40 (-40)	63 (145)	63 (145)	63 (145)	200 (392)	40 (104)	200 (392)	-40 (-40)	-40 (-40)	-40 (-40)	-	-

**FMR57**  
 Seal: Viton GLT  
 Housing: GT20 (Alu, coated)  
 Temperature unit: °C (°F)

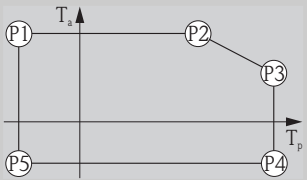

Power Supply; Output (Pos. 2 of the product structure)	P1		P2		P3		P4		P5		P6	
	T <sub>p</sub>	T <sub>a</sub>	T <sub>p</sub>	T <sub>a</sub>	T <sub>p</sub>	T <sub>a</sub>	T <sub>p</sub>	T <sub>a</sub>	T <sub>p</sub>	T <sub>a</sub>	T <sub>p</sub>	T <sub>a</sub>
A	-40 (-40)	81 (178)	81 (178)	81 (178)	200 (392)	70 (158)	200 (392)	-40 (-40)	-40 (-40)	-40 (-40)	-	-
B Switch output not used	-40 (-40)	82 (180)	82 (180)	82 (180)	200 (392)	70 (158)	200 (392)	-40 (-40)	-40 (-40)	-40 (-40)	-	-
B Switch output used	-40 (-40)	77 (171)	77 (171)	77 (171)	200 (392)	65 (149)	200 (392)	-40 (-40)	-40 (-40)	-40 (-40)	-	-
C Channel 2 not used	-40 (-40)	82 (180)	82 (180)	82 (180)	200 (392)	71 (160)	200 (392)	-40 (-40)	-40 (-40)	-40 (-40)	-	-
C Channel 2 used	-40 (-40)	79 (174)	79 (174)	79 (174)	200 (392)	67 (153)	200 (392)	-40 (-40)	-40 (-40)	-40 (-40)	-	-
E, G Switch output not used	-40 (-40)	83 (181)	83 (181)	83 (181)	200 (392)	71 (160)	200 (392)	-40 (-40)	-40 (-40)	-40 (-40)	-	-
E, G Schaltausgang verwende)	-40 (-40)	78 (172)	78 (172)	78 (172)	200 (392)	66 (151)	200 (392)	-40 (-40)	-40 (-40)	-40 (-40)	-	-
K, L	-40 (-40)	77 (171)	77 (171)	77 (171)	200 (392)	66 (151)	200 (392)	-40 (-40)	-40 (-40)	-40 (-40)	-	-

**FMR57**  
 Seal: Graphite  
 Housing: GT18 (316 L)  
 Temperature unit: °C (°F)

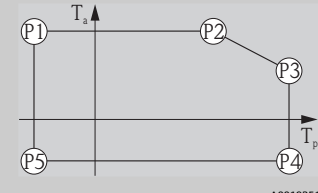

Power Supply; Output (Pos. 2 of the product structure)	P1		P2		P3		P4		P5		P6	
	T <sub>p</sub>	T <sub>a</sub>	T <sub>p</sub>	T <sub>a</sub>	T <sub>p</sub>	T <sub>a</sub>	T <sub>p</sub>	T <sub>a</sub>	T <sub>p</sub>	T <sub>a</sub>	T <sub>p</sub>	T <sub>a</sub>
A	-40 (-40)	81 (178)	81 (178)	81 (178)	400 (752)	51 (124)	400 (752)	-40 (-40)	-40 (-40)	-40 (-40)	-	-
B Switch output not used	-40 (-40)	82 (180)	82 (180)	82 (180)	400 (752)	51 (124)	400 (752)	-40 (-40)	-40 (-40)	-40 (-40)	-	-
B Switch output used	-40 (-40)	77 (171)	77 (171)	77 (171)	400 (752)	47 (117)	400 (752)	-40 (-40)	-40 (-40)	-40 (-40)	-	-
C Channel 2 not used	-40 (-40)	82 (180)	82 (180)	82 (180)	400 (752)	51 (124)	400 (752)	-40 (-40)	-40 (-40)	-40 (-40)	-	-
C Channel 2 used	-40 (-40)	79 (174)	79 (174)	79 (174)	400 (752)	49 (120)	400 (752)	-40 (-40)	-40 (-40)	-40 (-40)	-	-
E, G Switch output not used	-40 (-40)	83 (181)	83 (181)	83 (181)	400 (752)	51 (124)	400 (752)	-40 (-40)	-40 (-40)	-40 (-40)	-	-
E, G Switch output used	-40 (-40)	78 (172)	78 (172)	78 (172)	400 (752)	49 (120)	400 (752)	-40 (-40)	-40 (-40)	-40 (-40)	-	-
K, L	-40 (-40)	77 (171)	77 (171)	77 (171)	400 (752)	48 (118)	400 (752)	-40 (-40)	-40 (-40)	-40 (-40)	-	-

**FMR57**  
 Seal: Graphite  
 Housing: GT19 (Plastics PBT)  
 Temperature unit: °C (°F)

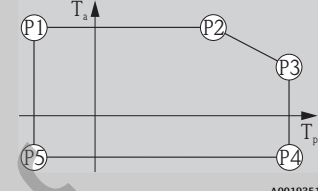

Power Supply; Output (Pos. 2 of the product structure)	P1		P2		P3		P4		P5		P6	
	T <sub>p</sub>	T <sub>a</sub>	T <sub>p</sub>	T <sub>a</sub>	T <sub>p</sub>	T <sub>a</sub>	T <sub>p</sub>	T <sub>a</sub>	T <sub>p</sub>	T <sub>a</sub>	T <sub>p</sub>	T <sub>a</sub>
A	-40 (-40)	80 (176)	80 (176)	80 (176)	400 (752)	15 (59)	400 (752)	-40 (-40)	-40 (-40)	-40 (-40)	-	-
B Switch output not used	-40 (-40)	76 (169)	76 (169)	76 (169)	400 (752)	15 (59)	400 (752)	-40 (-40)	-40 (-40)	-40 (-40)	-	-
B Switch output used	-40 (-40)	60 (140)	60 (140)	60 (140)	400 (752)	15 (59)	400 (752)	-40 (-40)	-40 (-40)	-40 (-40)	-	-
C Channel 2 not used	-40 (-40)	82 (180)	82 (180)	82 (180)	400 (752)	15 (59)	400 (752)	-40 (-40)	-40 (-40)	-40 (-40)	-	-
C Channel 2 used	-40 (-40)	74 (165)	74 (165)	74 (165)	400 (752)	15 (59)	400 (752)	-40 (-40)	-40 (-40)	-40 (-40)	-	-
E, G Switch output not used	-40 (-40)	79 (174)	79 (174)	79 (174)	400 (752)	15 (59)	400 (752)	-40 (-40)	-40 (-40)	-40 (-40)	-	-
E, G Switch output used	-40 (-40)	63 (145)	63 (145)	63 (145)	400 (752)	15 (59)	400 (752)	-40 (-40)	-40 (-40)	-40 (-40)	-	-

<b>FMR57</b> Seal: Graphite Housing: GT20 (Alu, coated) Temperature unit: °C (°F)												
Power Supply; Output (Pos. 2 of the product structure)	P1		P2		P3		P4		P5		P6	
	T <sub>p</sub>	T <sub>a</sub>	T <sub>p</sub>	T <sub>a</sub>	T <sub>p</sub>	T <sub>a</sub>	T <sub>p</sub>	T <sub>a</sub>	T <sub>p</sub>	T <sub>a</sub>	T <sub>p</sub>	T <sub>a</sub>
A	-40 (-40)	81 (178)	81 (178)	81 (178)	400 (752)	58 (136)	400 (752)	-40 (-40)	-40 (-40)	-40 (-40)	-	-
B Switch output not used	-40 (-40)	82 (180)	82 (180)	82 (180)	400 (752)	59 (138)	400 (752)	-40 (-40)	-40 (-40)	-40 (-40)	-	-
B Switch output used	-40 (-40)	77 (171)	77 (171)	77 (171)	400 (752)	53 (127)	400 (752)	-40 (-40)	-40 (-40)	-40 (-40)	-	-
C Channel 2 not used	-40 (-40)	82 (180)	82 (180)	82 (180)	400 (752)	59 (138)	400 (752)	-40 (-40)	-40 (-40)	-40 (-40)	-	-
C Channel 2 used	-40 (-40)	79 (174)	79 (174)	79 (174)	400 (752)	56 (133)	400 (752)	-40 (-40)	-40 (-40)	-40 (-40)	-	-
E, G Switch output not used	-40 (-40)	83 (181)	83 (181)	83 (181)	400 (752)	59 (138)	400 (752)	-40 (-40)	-40 (-40)	-40 (-40)	-	-
E, G Switch output used	-40 (-40)	78 (172)	78 (172)	78 (172)	400 (752)	55 (131)	400 (752)	-40 (-40)	-40 (-40)	-40 (-40)	-	-
K, L	-40 (-40)	77 (171)	77 (171)	77 (171)	400 (752)	54 (129)	400 (752)	-40 (-40)	-40 (-40)	-40 (-40)	-	-

**Storage temperature**      -40 to +80 °C (-40 to +176 °F)  
 -50 °C (-58 °F) with manufacturer declaration on request

**Climate class**                      DIN EN 60068-2-38 (test Z/AD)

**Altitude according to IEC61010-1 Ed.3**      Up to 2 000 m (6 600 ft) above MSL.

**Degree of protection**

- With closed housing tested according to:
  - IP68, NEMA6P (24 h at 1.83 m under water surface)<sup>4)</sup>
  - For plastic housing with transparent cover (display module): IP68 (24 h at 1.00 m under water surface)<sup>5)</sup>
  - IP66, NEMA4X
- With open housing: IP20, NEMA1
- Display module: IP22, NEMA2

Degree of protection IP68 NEMA6P applies for M12 PROFIBUS PA plugs only when the PROFIBUS cable is plugged in and is also rated IP68 NEMA6P.

**Vibration resistance**              DIN EN 60068-2-64 / IEC 60068-2-64: 20 to 2 000 Hz, 1 (m/s<sup>2</sup>)<sup>2</sup>/Hz

**Cleaning the antenna**              The antenna can get contaminated, depending on the application. The emission and reception of microwaves can thus eventually be hindered. The degree of contamination leading to an error depends on the medium and the reflectivity, mainly determined by the dielectric constant  $\epsilon_r$ .

If the medium tends to cause contamination and deposits, cleaning on a regular basis is recommended. In the case of FRM57, the integrated air purge connection can be used for this → 41. Care has to be taken not to damage the antenna in the process of a mechanical or hose-

4) also valid for the "Sensor remote" version  
 5) This restriction is valid if the following options of the product structure have been selected at the same time: 030("Display, Operation") = C("SD02") or E("SD03"); 040("Housing") = A("GT19").

down cleaning. The material compatibility has to be considered if cleaning agents are used! The maximum permitted temperature at the flange should not be exceeded.

---

**Electromagnetic compatibility (EMC)**

Electromagnetic compatibility to all relevant requirements of the EN 61326- series and NAMUR recommendation EMC (NE21). For details see declaration of conformity.<sup>6)</sup>

If only the analogue signal is used, unshielded interconnection lines are sufficient for the installation. In case of using the digital signal (HART/ PA/ FF) use shielded interconnection lines.

Max. fluctuations during EMC- tests: < 0.5 % of the span. As an exception to this, the maximum fluctuations may amount to 2 % of the span for devices with plastic housing and see-through lid (integrated display SD02 or SD03) if strong electromagnetic interferences in the frequency range of 1 to 2 GHz are present.

ТЕХНОДИЗАЙН-М

---

6) Can be downloaded from [www.endress.com](http://www.endress.com).



## Process

### Process temperature, Process pressure



The specified pressure range may be reduced due to the selected process connection. The pressure rating (PN) specified on the flanges refers to a reference temperature of 20 °C, for ASME flanges 100 °F. Pay attention to pressure-temperature dependencies.

Please refer to the following standards for the pressure values permitted for higher temperatures:

- EN 1092-1: 2001 Tab. 18

With regard to their temperature stability properties, the materials 1.4435 and 1.4404 are grouped under 13E0 in EN 1092-1 Tab. 18. The chemical composition of the two materials can be identical.

- ASME B 16.5a - 1998 Tab. 2-2.2 F316
- ASME B 16.5a - 1998 Tab. 2.3.8 N10276
- JIS B 2220

### FMR56

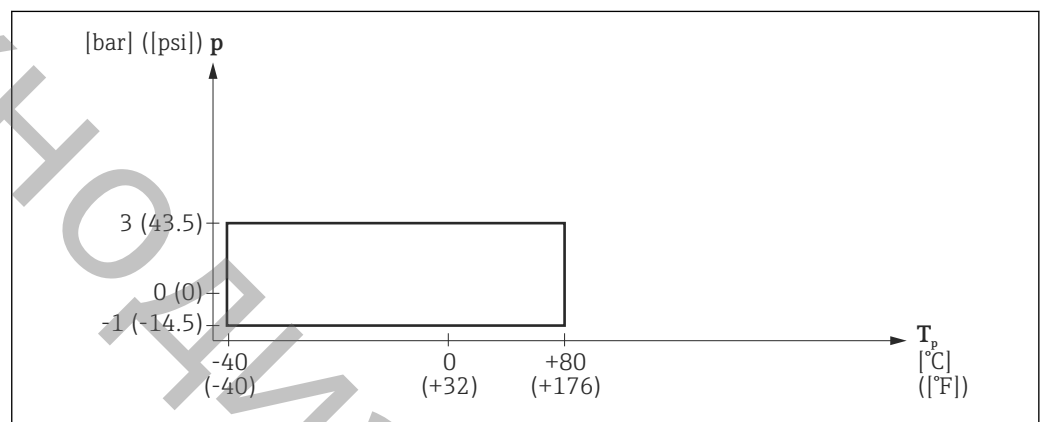

A0023252-EN

18 FMR56: Admissible range of process temperature and process pressure

Device version	Admissible process temperature	Admissible process pressure
All versions	-40 to +80 °C (-40 to +176 °F)	$p_{rel} = -1$ to 3 bar (-14.5 to 43.5 psi) $p_{abs} < 4$ bar (58 psi) <sup>1)</sup>

1) For devices with CRN approval the pressure range may be reduced → 77

### FMR57

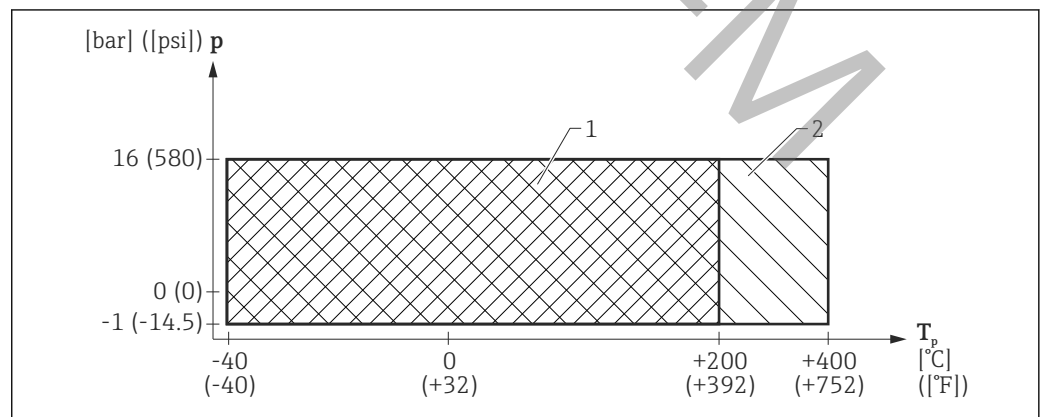

A0023253-EN

19 FMR57: Admissible range of process temperature and process pressure

- Seal: Viton GLT (Feature 090 "Seal", Option A6)
- Seal: Graphite (Feature 090 "Seal", Option D4)

Feature 090 "Seal"	Admissible process temperature	Admissible process pressure
A6: Viton GLT	-40 to +200 °C (-40 to +392 °F)	p <sub>rel</sub> = -1 to 16 bar (-14.5 to 232 psi)
D4: Graphite	-40 to +400 °C (-40 to +752 °F)	

#### Dielectric constant

- **For liquids**

- $\epsilon_r \geq 1.9$  in free-field applications
- $\epsilon_r \geq 1.4$  in stilling well

- **For bulk solids**

$$\epsilon_r \geq 1.6$$

 For dielectric constants (DC values) of many media commonly used in various industries refer to:

- the Endress+Hauser DC manual (CP01076F)
- the Endress+Hauser "DC Values App" (available for Android and iOS)

## Mechanical construction

### Dimensions

#### Dimensions of the electronics housing

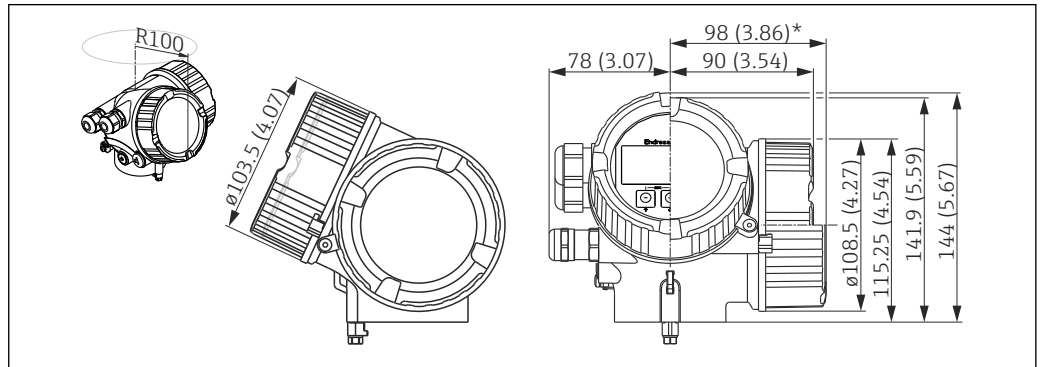

A0011666

20 Housing GT18 (316L); Dimensions in mm (in)

\*for devices with integrated overvoltage protection.

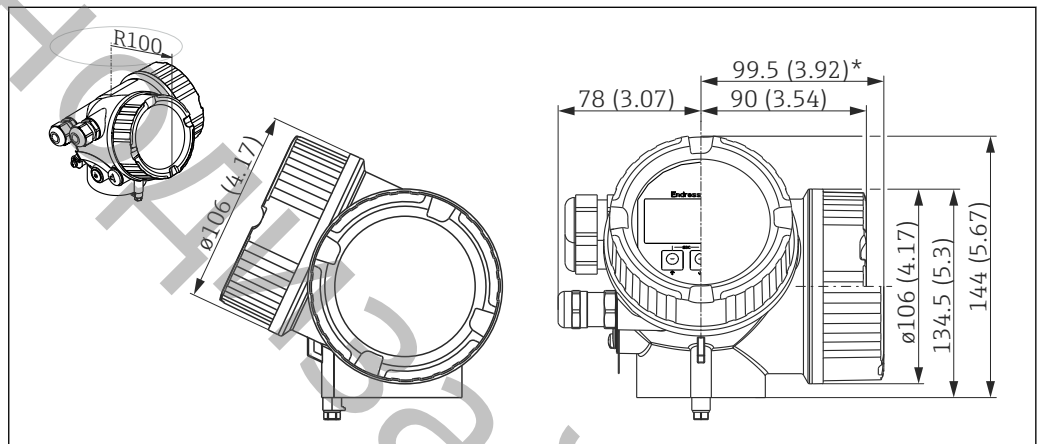

A0011346

21 Housing GT19 (Plastics PBT); Dimensions in mm (in)

\*for devices with integrated overvoltage protection.

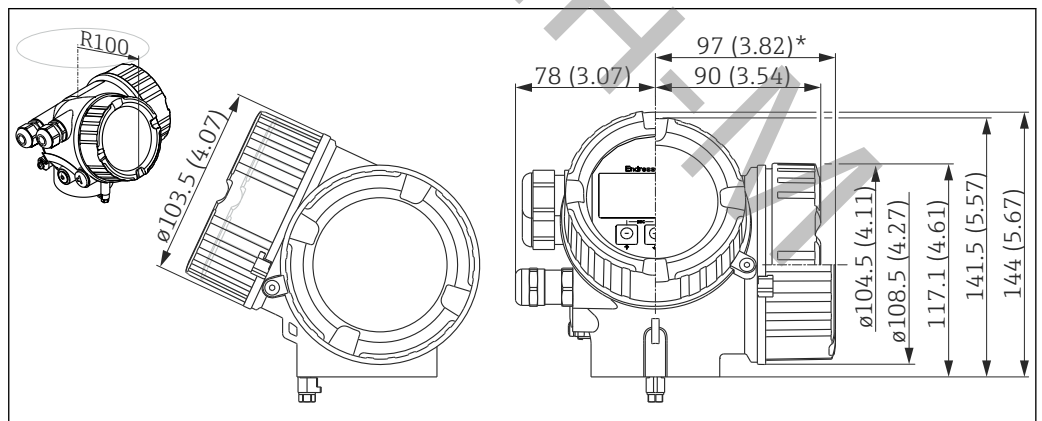

A0020751

22 Housing GT20 (Alu coated); Dimensions in mm (in)

\*for devices with integrated overvoltage protection.

FMR56 with mounting bracket or customer side connection

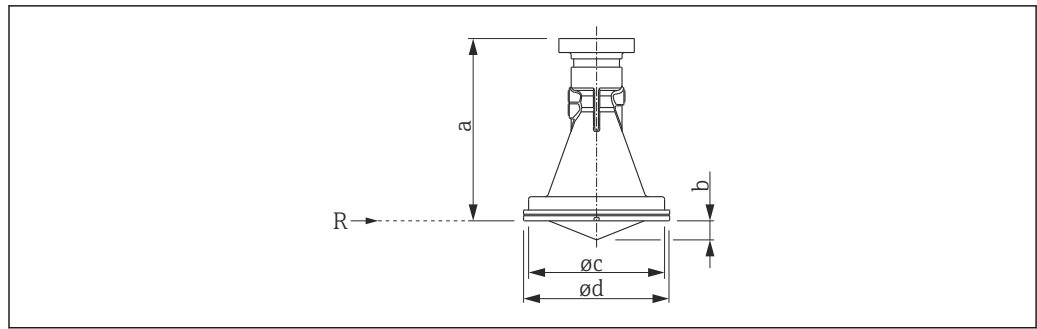

A0017747

23 FMR56 without process connection; dimensions: mm (in)

R Reference point of the measurement

	Feature 100 "Process connection"	
	<ul style="list-style-type: none"> <li>▪ UAE: Mounting bracket</li> <li>▪ XRO: Customer side connection</li> </ul>	
	Feature 070 "Antenna" BN: Horn 80mm/3"	Feature 070 "Antenna" BR: Horn 100mm/4"
a	137.9 mm (5.43 in)	150.5 mm (5.93 in)
b	15 mm (0.59 in)	20 mm (0.79 in)
øc	107 mm (4.21 in)	127 mm (5 in)
ød	115 mm (4.53 in)	135 mm (5.31 in)

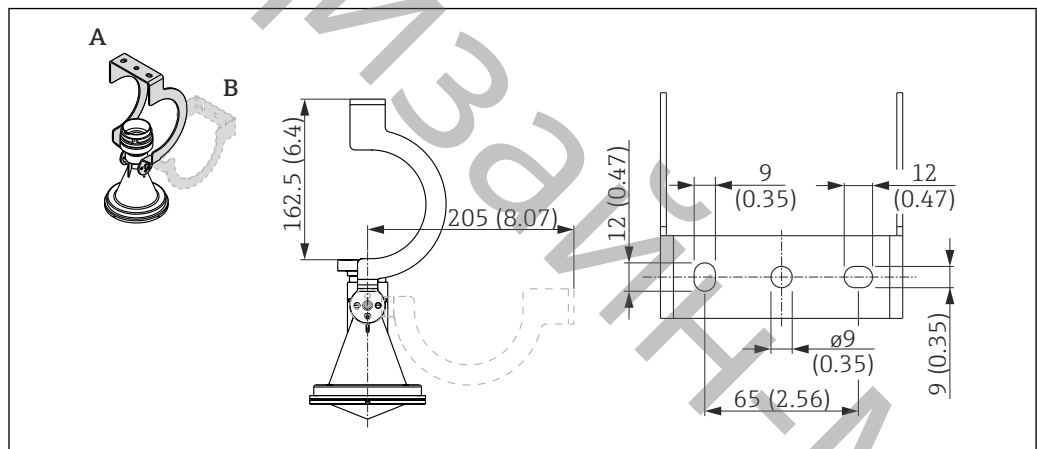

A0017746

24 Mounting bracket for FMR50/FMR56; dimensions: mm (in)

A Mounting bracket aligned for roof mounting  
 B Mounting bracket aligned for wall mounting

FMR56 with slip-on flange 3"/DN80

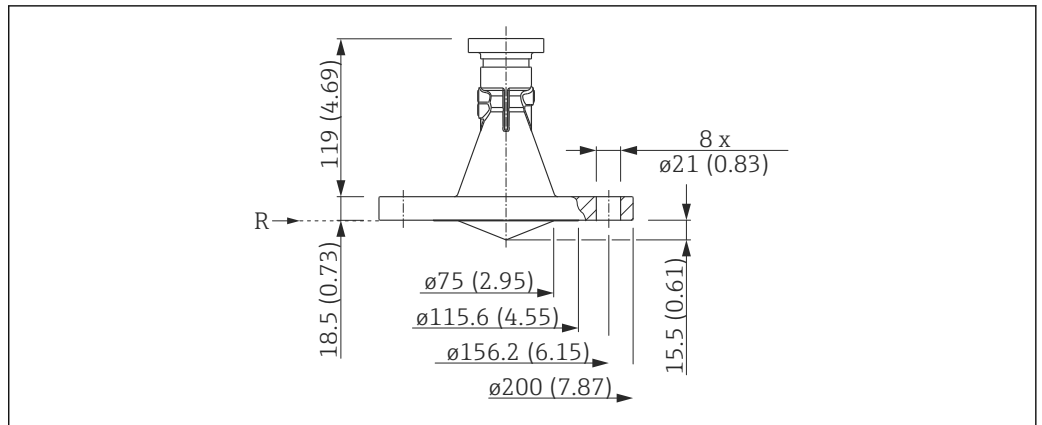

A0023377

25 FMR56 with slip-on flange 3"/DN80; dimensions: mm (in)

R Reference point of the measurement

Valid for the following device versions

- **Feature 100 "Process connection"**  
XWG: UNI slip-on flange 3"/DN80, PP
- **Feature 070 "Antenna"**  
BN: Horn 80mm/3", PP cladded

- **i** The UNI slip-on flange is suitable for:
  - ASME: NPS 3" Cl.150
  - EN: DN80 PN16
  - JIS: 10K 80

## FMR56 with slip-on flange 4"/DN100

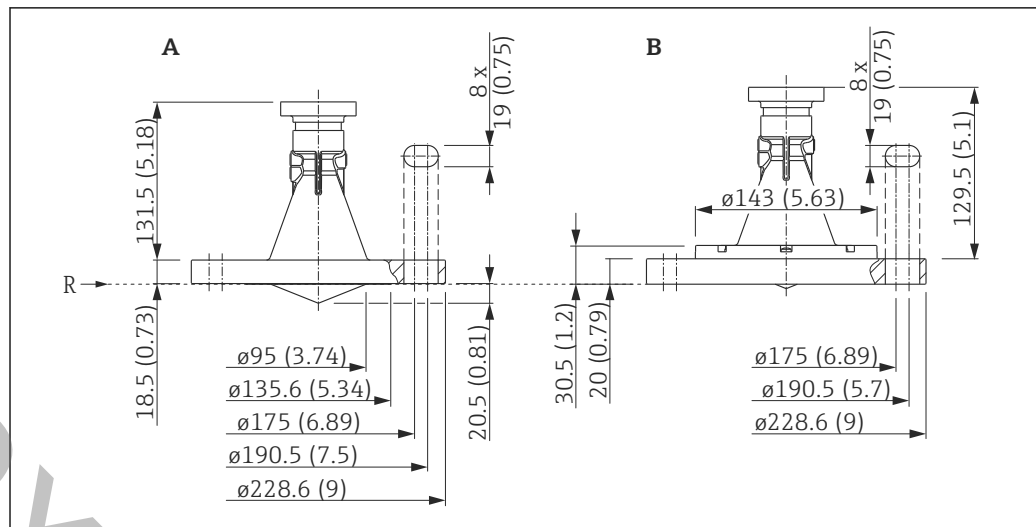

A0023379

26 FMR56 with slip-on flange 4"/DN100; dimensions: mm (in)

- A Horn antenna 100mm/4" (without adapter ring)  
 B Horn antenna 80mm/3" (with adapter ring)  
 R Reference point of the measurement

## Valid for the following device versions

- Feature 100 "Process connection":  
 XZG: UNI slip-on flange 4"/DN100
- Feature 070 "Antenna":
  - BR: Horn 100mm/4", PP clad (diagram A)
  - BN: Horn 80mm/3", PP clad (diagram B)

**i** The UNI slip-on flange is suitable for:

- ASME: NPS 4" Cl.150
- EN: DN100 PN16
- JIS: 10K 100

FMR56 with slip-on flange 6"/DN150

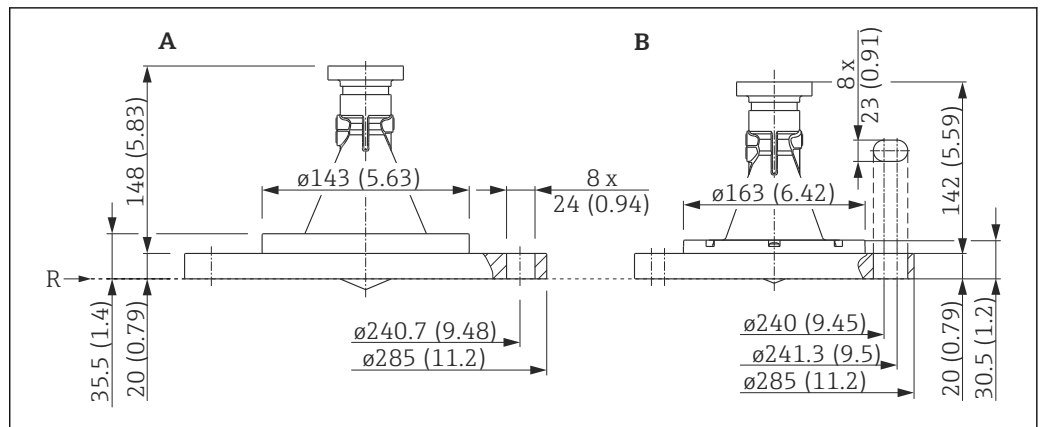

A0023380

27 FMR56 with slip-on flange 6"/DN150; dimensions: mm (in)

- A Horn antenna 100mm/4"
- B Horn antenna 80mm/3"
- R Reference point of the measurement

Valid for the following device versions

- **Feature 100 "Process connection":**  
XOG: UNI slip-on flange 6"/DN150, PP
- **Feature 070 "Antenna":**
  - BR: Horn 100mm/4", PP clad (diagram A)
  - BN: Horn 80mm/3", PP clad (diagram B)

- **i** The UNI slip-on flange is suitable for:
  - ASME: NPS 6" Cl.150
  - EN: DN150 PN16
  - JIS: 10K 150

FMR57 with horn antenna - standard version

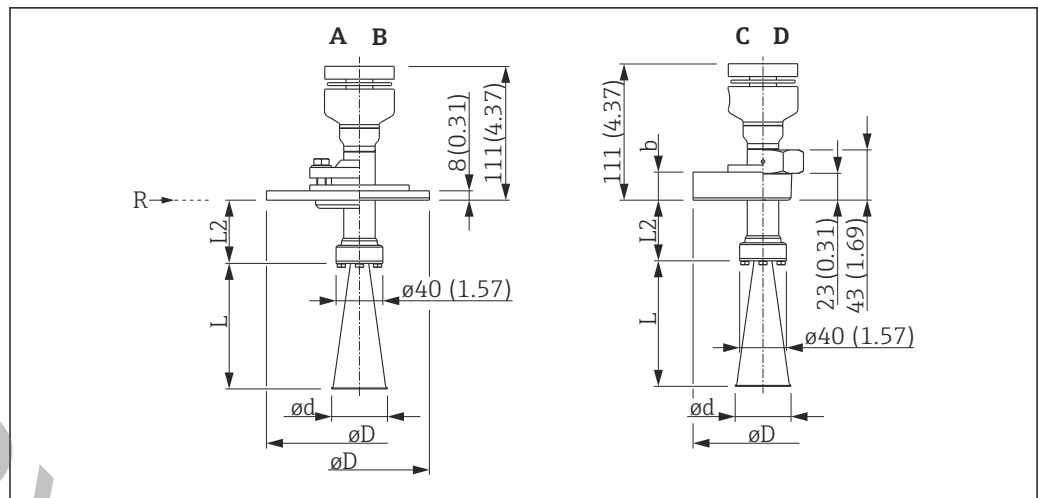

A0023392

28 FMR57 with horn antenna - standard version; dimensions: mm(in)

- A Process connection: Alignment device with UNI flange
- B Process connection: UNI flange
- C Process connection: flange
- D Process connection: Thread MNPT1-1/2 or R1-1/2
- R Reference point of the measurement

Valid for the following device versions

- Feature 070 "Antenna"
  - BC: Horn 80mm/3"
  - BD: Horn 100mm/4"
- Feature 090 "Seal"
  - A6: Viton GLT, -40...200°C/-40...392°F

Dimensions of the antenna

Dimension	Feature 070 "Antenna"	
	BC: Horn 80mm/3"	BD: Horn 100mm/4"
L	211 mm (8.37 in)	430 mm (16.9 in)
ød	ø75 mm (2.95 in)	ø95 mm (3.74 in)
L2	50 mm (1.97 in)	50 mm (1.97 in)
	for version with 250 mm (10 in) antenna extension <sup>1)</sup> :	
	300 mm (11.8 in)	300 mm (11.8 in)
L2	for version with 450 mm (18 in) antenna extension:	
	500 mm (19.7 in)	500 mm (19.7 in)

1) Product structure: Feature 610: "Accessory Mounted"

**i** Dimensions of the flange (b, øD): → 59



FMR57 with horn antenna - high temperature version

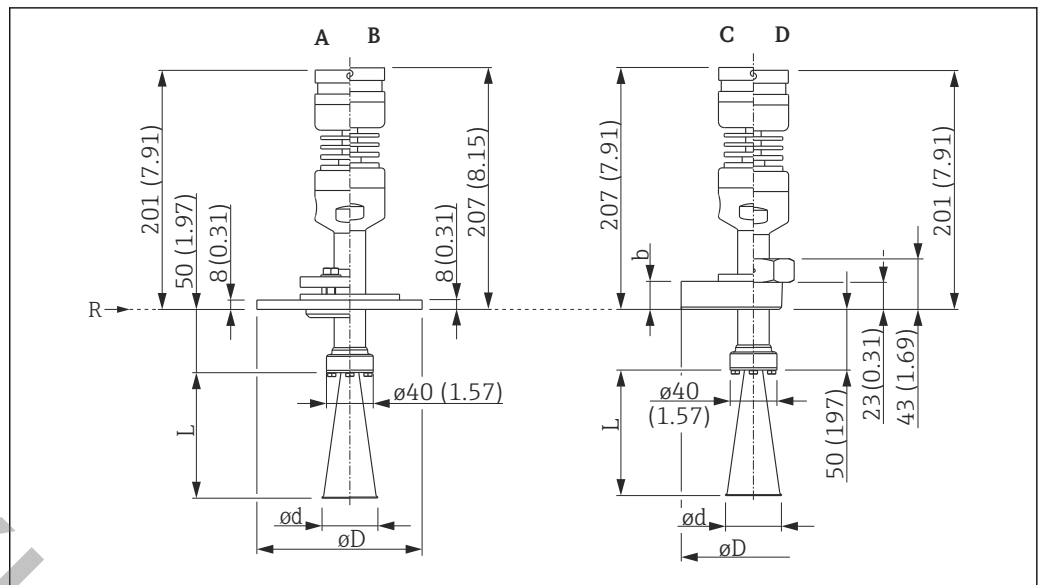

29 FMR57 with horn antenna - high temperature version; dimensions: mm(in)

- A Process connection: Alignment unit with UNI flange
- B Process connection: UNI flange
- C Process connection: Flange
- D Process connection: Thread MNPT1-1/2 or R1-1/2
- R Reference point of the measurement

Valid for the following device versions

- Feature 070 "Antenna"
  - BC: Horn 80mm/3"
  - BD: Horn 100mm/4"
- Feature 090 "Seal"
  - D4: Graphite, -40...400°C/-40...752°F

Horn antenna

Dimension	Feature 070 "Antenna"	
	BC: Horn 80mm/3"	BD: Horn 100mm/4"
L	211 mm (8.37 in)	430 mm (16.9 in)
ød	ø75 mm (2.95 in)	ø95 mm (3.74 in)

Dimensions for the flanges (b, øD): → 59

FMR57 with parabolic antenna

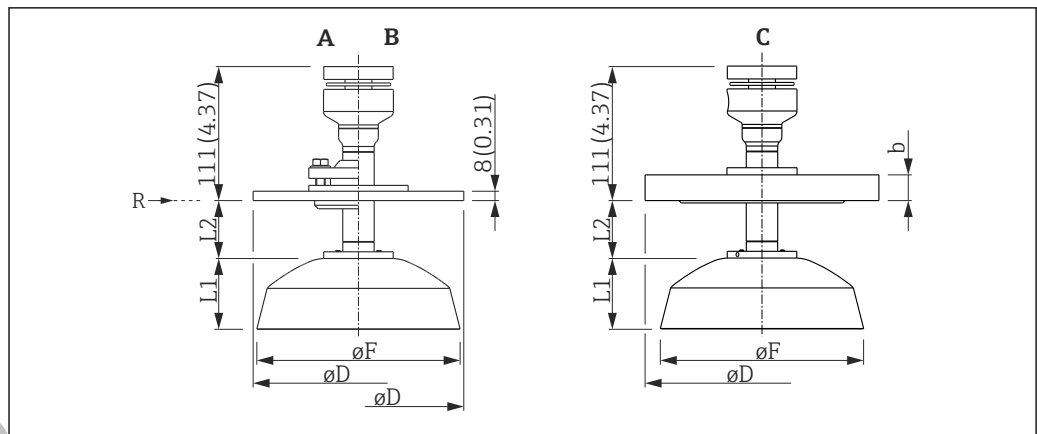

A0023393

30 FMR57 with parabolic antenna; dimensions: mm(in)

- A Process connection: Alignment unit with UNI flange
- B Process connection: UNI flange
- C Process connection: Flange
- R Reference point of the measurement

Dimension	Feature 070 "Antenna"	
	FA: Parabolic 200 mm/8"	FB: Parabolic 250 mm/10"
L1	60.6 mm (2.39 in)	88.4 mm (3.48 in)
øF	ø173 mm (6.81 in)	ø236 mm (9.29 in)
L2	50 mm (1.97 in)	37 mm (1.46 in)
	for version with 250 mm (10 in) antenna extension <sup>1)</sup> :	
	300 mm (11.8 in)	287 mm (11.3 in)
L2	for version with 450 mm (18 in) antenna extension <sup>1)</sup> :	
	500 mm (19.7 in)	487 mm (19.2 in)

1) Product structure: Feature 610: "Accessory Mounted"

**i** Dimensions of the flanges (b, øD): → 59

**FMR57: Dimensions of the flanges**

*Flanges according to EN1092-1 (suitable for DIN2527)*

Pressure rating <sup>1)</sup>	Dimension	Nominal diameter <sup>1)</sup>	
		DN80	DN100
PN10/16	b	20 mm (0.79 in)	20 mm (0.79 in)
	φD	φ200 mm (7.87 in)	φ220 mm (8.66 in)

1) Feature 100 of the product structure

*Flanges according to ASME B16.5*

Pressure rating <sup>1)</sup>	Dimension	Nominal diameter <sup>1)</sup>	
		3"	4"
Cl. 150	b	23.9 mm (0.94 in)	23.9 mm (0.94 in)
	φD	φ190.5 mm (7.5 in)	φ228.6 mm (9 in)

1) Feature 100 of the product structure

*Flanges according to JIS B2220*

Pressure rating <sup>1)</sup>	Dimension	Nominal diameter <sup>1)</sup>	
		DN80	DN100
10 K	b	18 mm (0.71 in)	18 mm (0.71 in)
	φD	φ185 mm (7.28 in)	φ210 mm (8.27 in)

1) Feature 100 of the product structure

Endress+Hauser UNI flanges

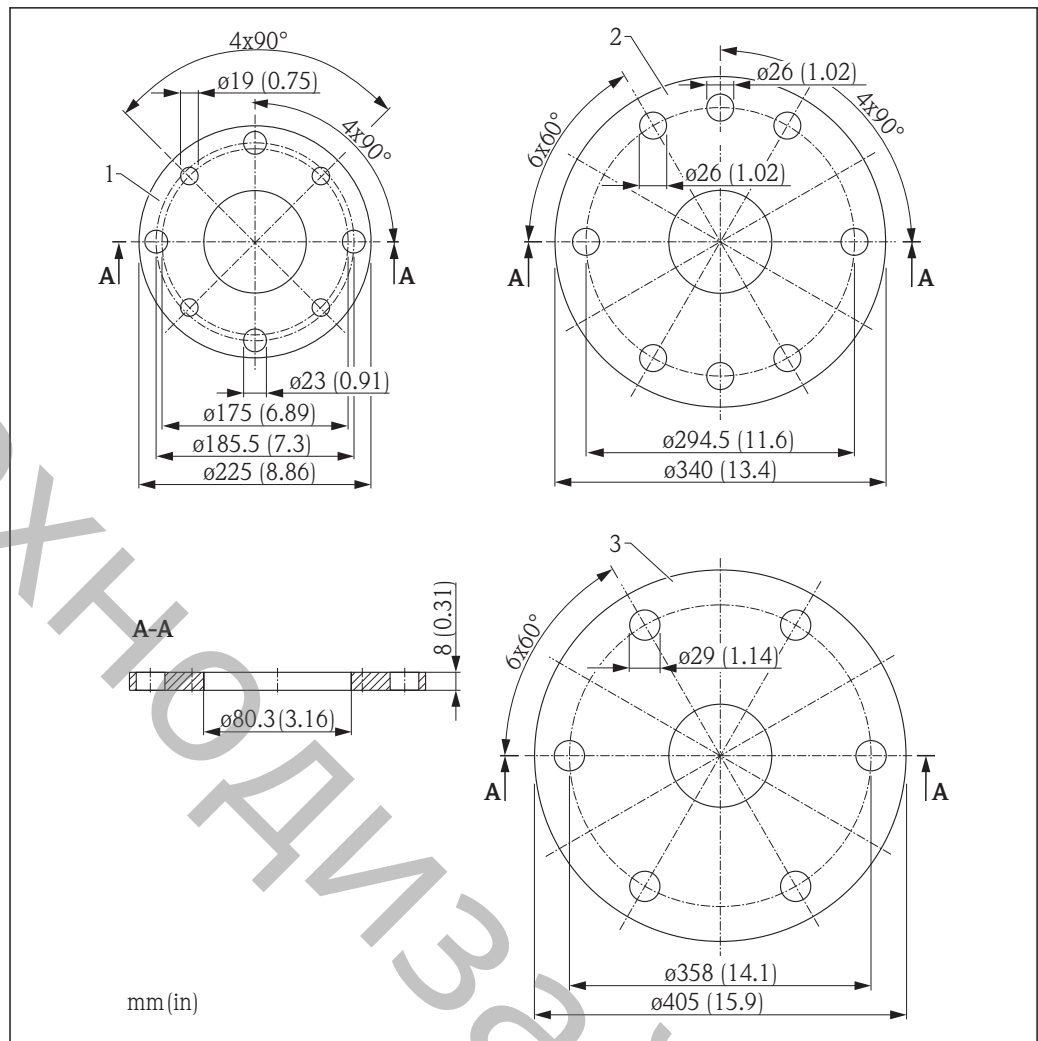

A0018947

Pos.	Feature 100: Process connection	Suitable for	Material
1:	XCJ: Alignment device, UNI 4"/DN100	<ul style="list-style-type: none"> <li>■ 4" 150lbs</li> <li>■ DN100 PN16/PN25/PN40</li> <li>■ 10K/16K/20K 100</li> </ul>	316L (1.4404)
2:	<ul style="list-style-type: none"> <li>■ XEJ: Alignment device, UNI 8"/DN200</li> <li>■ X3J: UNI flange DN200/8"</li> </ul>	<ul style="list-style-type: none"> <li>■ 8" 150lbs</li> <li>■ DN200 PN16</li> <li>■ 10K 200</li> </ul>	316L (1.4404)
3:	<ul style="list-style-type: none"> <li>■ XFJ: Alignment device, UNI 10"/DN250</li> <li>■ X5J: UNI flange DN250/10"</li> </ul>	<ul style="list-style-type: none"> <li>■ 10" 150lbs</li> <li>■ DN250 PN16</li> <li>■ 10K 250</li> </ul>	316L (1.4404)

**i** The number of bolts is reduced in some cases. To match different standards the bores are enlarged. Therefore the bolts should be aligned centrally to the counter flange before tightening.

Alignment device with Endress+Hauser UNI flange

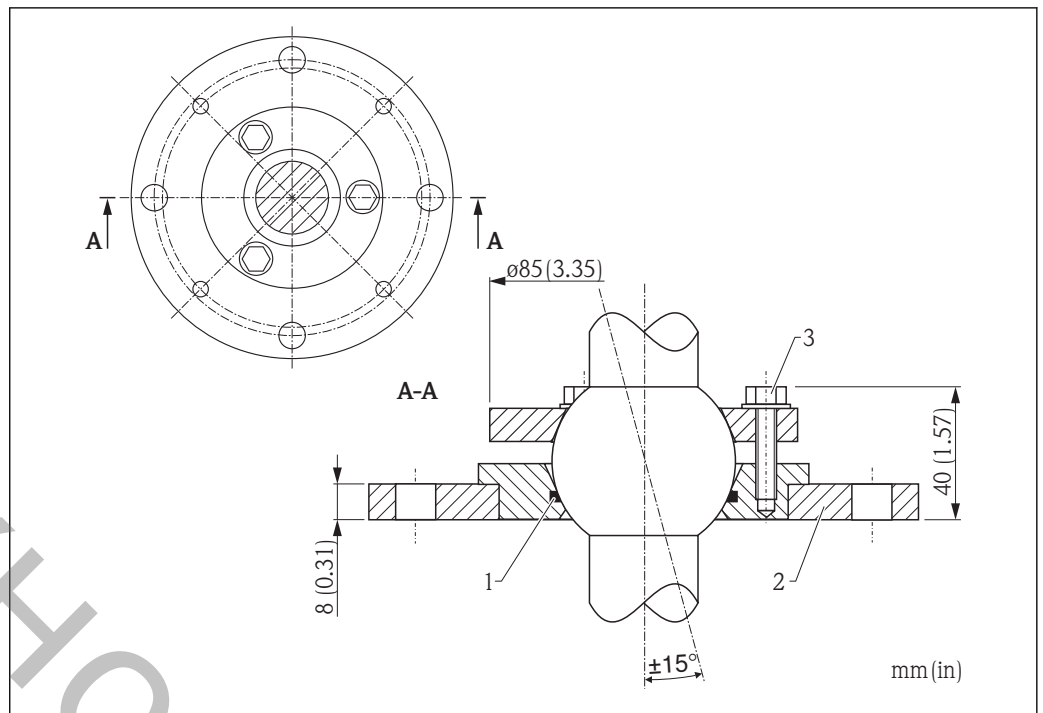

- 1 Viton seal
- 2 Endress+Hauser UNI flange DN100/200/250
- 3 Clamping screws 3 x M8, (displaced by an angle of 120° from each other)

**i** For the high temperature version of the FMR57 (sales option 090: "Seal", option D4 "Graphite, -40...400°C / -40...752°F"), there is no Viton seal (1) at the alignment device.

Weight

Housing

Part	Weight
Housing GT18 - stainless steel	approx. 4.5 kg (9.9 lb)
Housing GT19 - plastic	approx. 1.2 kg (2.7 lb)
Housing GT20 - aluminium	approx. 1.9 kg (4.2 lb)

Antenna and process connection

Device	Weight of antenna and process connection
FMR56	max. 1.5 kg (3.3 lb) + weight of flange <sup>1)</sup>
FMR57	max. 5.5 kg (12.1 lb) + weight of flange <sup>1)</sup>

1) For the weight of the flange refer to Technical Information TI00426F.

## Materials: GT18 housing

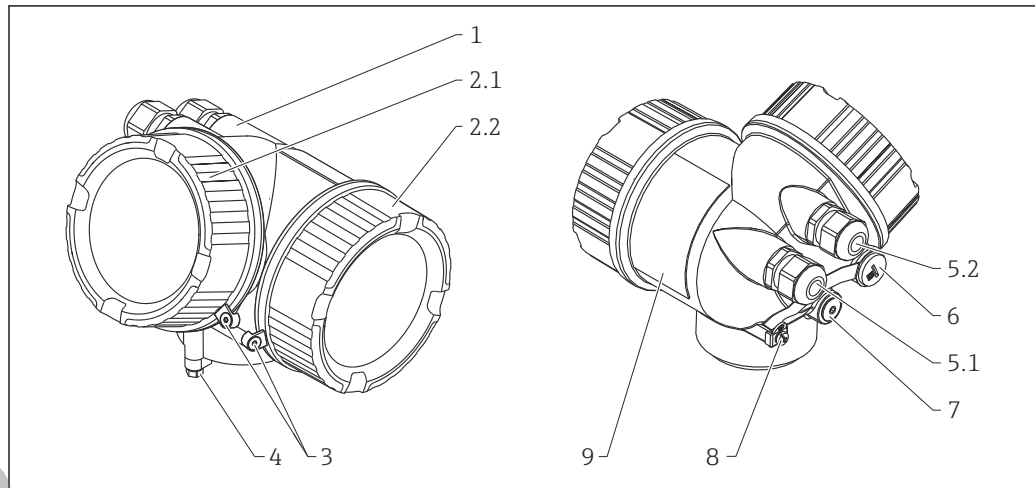

A0013788

No.	Part	Material
1	Housing	CF-3M (316L, 1.4404)
2.1	Cover of the electronics compartment	<ul style="list-style-type: none"> <li>▪ Cover: CF-3M (316L, 1.4404)</li> <li>▪ Window: glass</li> <li>▪ Cover seal: EPDM</li> <li>▪ Seal of the window: NBR</li> <li>▪ Thread-coating: Graphite-based lubricant varnish</li> </ul>
2.2	Cover of the terminal compartment	<ul style="list-style-type: none"> <li>▪ Cover: CF-3M (316L, 1.4404)</li> <li>▪ Cover seal: EPDM</li> <li>▪ Thread-coating: Graphite-based lubricant varnish</li> </ul>
3	Cover lock	<ul style="list-style-type: none"> <li>▪ Screw: A4</li> <li>▪ Clamp: 316L (1.4404)</li> </ul>
4	Lock at the housing neck	<ul style="list-style-type: none"> <li>▪ Screw: A4-70</li> <li>▪ Clamp: 316L (1.4404)</li> </ul>
5.1	Dummy plug, cable gland, adapter or plug (depending on the device version)	<ul style="list-style-type: none"> <li>▪ Dummy plug, depending on the device version: <ul style="list-style-type: none"> <li>- PE</li> <li>- PBT-GF</li> </ul> </li> <li>▪ Cable gland: 316L (1.4404) or nickel-plated brass</li> <li>▪ Adapter: 316L (1.4404/1.4435)</li> <li>▪ Seal: EPDM</li> <li>▪ M12 plug: Nickel-plated brass <sup>1)</sup></li> <li>▪ 7/8" plug: 316 (1.4401) <sup>2)</sup></li> </ul>
5.2	Dummy plug, cable gland or adapter (depending on the device version)	<ul style="list-style-type: none"> <li>▪ Dummy plug: 316L (1.4404)</li> <li>▪ Cable gland: 316L (1.4404) or nickel-plated brass</li> <li>▪ Adapter: 316L (1.4404/1.4435)</li> <li>▪ Seal: EPDM</li> </ul>
6	Dummy plug or M12 socket (depending on the device version)	<ul style="list-style-type: none"> <li>▪ Dummy plug: 316L (1.4404)</li> <li>▪ M12 socket: 316L (1.4404)</li> </ul>
7	Pressure relief stopper	316L (1.4404)
8	Ground terminal	<ul style="list-style-type: none"> <li>▪ Screw: A4</li> <li>▪ Spring washer: A4</li> <li>▪ Clamp: 316L (1.4404)</li> <li>▪ Holder: 316L (1.4404)</li> </ul>
9	Nameplate	<ul style="list-style-type: none"> <li>▪ Plate: 316L (1.4404)</li> <li>▪ Groove pin: A4 (1.4571)</li> </ul>

1) For the version with M12 plug the sealing material is Viton.

2) For the version with 7/8" plug, the sealing material is NBR.

Materials: GT19 housing

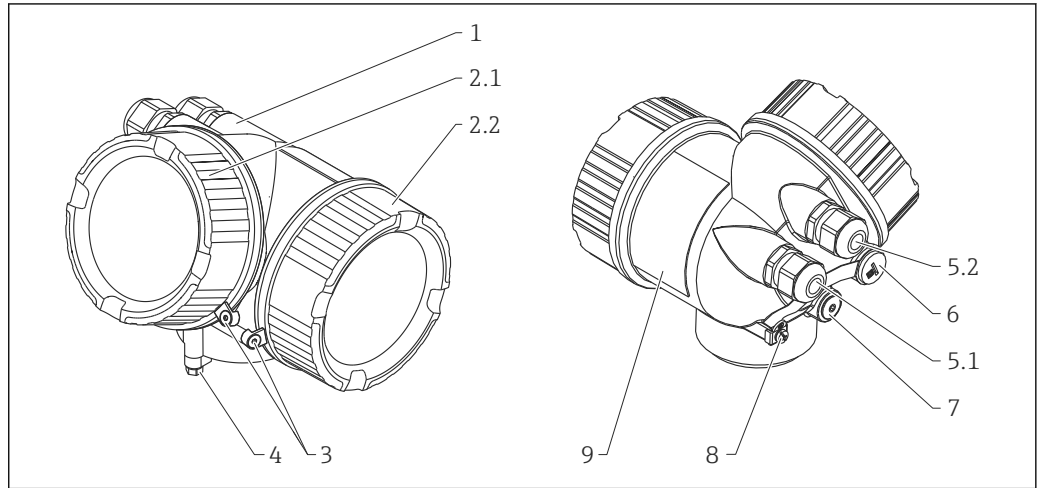

A0013788

No.	Part	Material
1	Housing	PBT
2.1	Cover of the electronics compartment	<ul style="list-style-type: none"> <li>▪ Cover, depending on the device version:                             <ul style="list-style-type: none"> <li>- PA (see-through cover)</li> <li>- PBT (non-transparent cover)</li> </ul> </li> <li>▪ Cover seal: EPDM</li> <li>▪ Thread-coating: Graphite-based lubricant varnish</li> </ul>
2.2	Cover of the terminal compartment	<ul style="list-style-type: none"> <li>▪ Cover: PBT</li> <li>▪ Cover seal: EPDM</li> <li>▪ Thread-coating: Graphite-based lubricant varnish</li> </ul>
4	Lock at the housing neck	<ul style="list-style-type: none"> <li>▪ Screw: A4-70</li> <li>▪ Clamp: 316L (1.4404)</li> </ul>
5.1	Dummy plug, cable gland, adapter or plug (depending on the device version)	<ul style="list-style-type: none"> <li>▪ Dummy plug, depending on the device version:                             <ul style="list-style-type: none"> <li>- PE</li> <li>- PBT-GF</li> </ul> </li> <li>▪ Cable gland, depending on the device version:                             <ul style="list-style-type: none"> <li>- Nickel-plated brass (CuZn)</li> <li>- PA</li> </ul> </li> <li>▪ Adapter: 316L (1.4404/1.4435)</li> <li>▪ Seal: EPDM</li> <li>▪ M12 plug: Nickel-plated brass <sup>1)</sup></li> <li>▪ 7/8" plug: 316 (1.4401) <sup>2)</sup></li> </ul>
5.2	Dummy plug, cable gland or adapter (depending on the device version)	<ul style="list-style-type: none"> <li>▪ Dummy plug, depending on the device version:                             <ul style="list-style-type: none"> <li>- PE</li> <li>- PBT-GF</li> <li>- Nickel-plated steel</li> </ul> </li> <li>▪ Cable gland, depending on the device version:                             <ul style="list-style-type: none"> <li>- Nickel-plated brass (CuZn)</li> <li>- PA</li> </ul> </li> <li>▪ Adapter: 316L (1.4404/1.4435)</li> <li>▪ Seal: EPDM</li> </ul>
6	Dummy plug or M12 socket (depending on the device version)	<ul style="list-style-type: none"> <li>▪ Dummy plug: Nickel-plated brass (CuZn)</li> <li>▪ M12 socket: Nickel-plated GD-Zn</li> </ul>
7	Pressure relief stopper	Nickel-plated brass (CuZn)
8	Ground terminal	<ul style="list-style-type: none"> <li>▪ Screw: A2</li> <li>▪ Spring washer: A4</li> <li>▪ Clamp: 304 (1.4301)</li> <li>▪ Holder: 304 (1.4301)</li> </ul>
9	Nameplate	Sticker

1) For the version with M12 plug the sealing material is Viton.

2) For the version with 7/8" plug, the sealing material is NBR.

Materials: GT20 housing

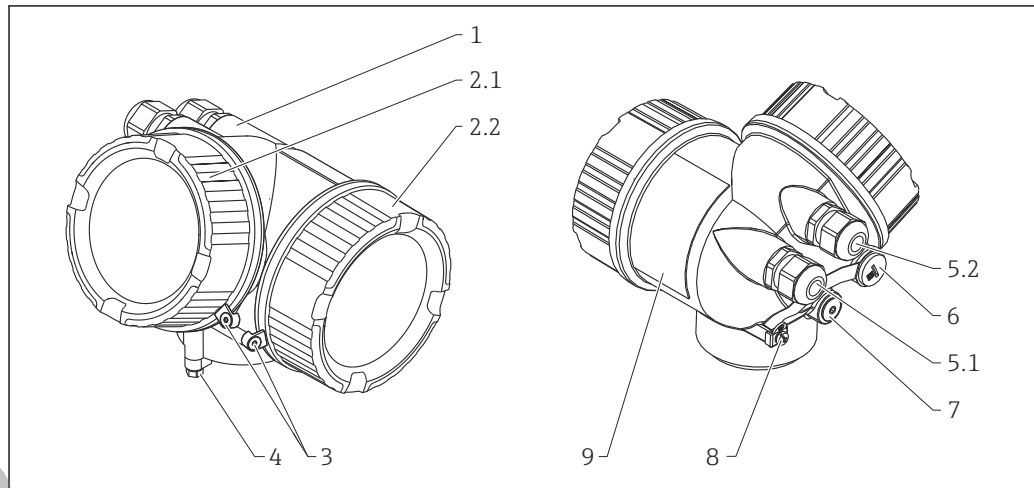

A0013788

Nr.	Part	Material
1	Housing, RAL 5012 (blue)	<ul style="list-style-type: none"> <li>■ Housing: AlSi10Mg(&lt;0,1% Cu)</li> <li>■ Coating: Polyester</li> </ul>
2.1	Cover of the electronics compartment; RAL 7035 (gray)	<ul style="list-style-type: none"> <li>■ Cover: AlSi10Mg(&lt;0,1% Cu)</li> <li>■ Window: Glass</li> <li>■ Cover seal: EPDM</li> <li>■ Seal of the window: NBR</li> <li>■ Thread-coating: Graphite-based lubricant varnish</li> </ul>
2.2	Cover of the terminal compartment; RAL 7035 (gray)	<ul style="list-style-type: none"> <li>■ Cover: AlSi10Mg(&lt;0,1% Cu)</li> <li>■ Cover seal: EPDM</li> <li>■ Thread-coating: Graphite-based lubricant varnish</li> </ul>
3	Cover lock	<ul style="list-style-type: none"> <li>■ Screw: A4</li> <li>■ Clamp: 316L (1.4404)</li> </ul>
4	Lock at the housing neck	<ul style="list-style-type: none"> <li>■ Screw: A4-70</li> <li>■ Clamp: 316L (1.4404)</li> </ul>
5.1	Dummy plug, cable gland, adapter or plug (depending on the device version)	<ul style="list-style-type: none"> <li>■ Dummy plug, depending on the device version:                             <ul style="list-style-type: none"> <li>- PE</li> <li>- PBT-GF</li> </ul> </li> <li>■ Cable gland, depending on the device version:                             <ul style="list-style-type: none"> <li>- Nickel-plated brass (CuZn)</li> <li>- PA</li> </ul> </li> <li>■ Adapter: 316L (1.4404/1.4435)</li> <li>■ Seal: EPDM</li> <li>■ M12 plug: Nickel-plated brass <sup>1)</sup></li> <li>■ 7/8" plug: 316 (1.4401) <sup>2)</sup></li> </ul>
5.2	Dummy plug, cable gland or adapter (depending on the device version)	<ul style="list-style-type: none"> <li>■ Dummy plug, depending on the device version:                             <ul style="list-style-type: none"> <li>- PE</li> <li>- PBT-GF</li> <li>- Nickel-plated steel</li> </ul> </li> <li>■ Cable gland, depending on the device version:                             <ul style="list-style-type: none"> <li>- Nickel-plated brass (CuZn)</li> <li>- PA</li> </ul> </li> <li>■ Adapter: 316L (1.4404/1.4435)</li> <li>■ Seal: EPDM</li> </ul>
6	Dummy plug or M12 socket (depending on the device version)	<ul style="list-style-type: none"> <li>■ Dummy plug : Nickel-plated brass (CuZn)</li> <li>■ M12 socket: Nickel-plated GD-Zn</li> </ul>
7	Pressure relief stopper	Nickel-plated brass (CuZn)



Nr.	Part	Material
8	Ground terminal	<ul style="list-style-type: none"> <li>■ Screw: A2</li> <li>■ Spring washer: A2</li> <li>■ Clamp: 304 (1.4301)</li> <li>■ Holder: 304 (1.4301)</li> </ul>
9	Nameplate	Sticker

- 1) For the version with M12 plug the sealing material is Viton.
- 2) For the version with 7/8" plug, the sealing material is NBR.

**Materials: Antenna and process connection**

**FMR56**

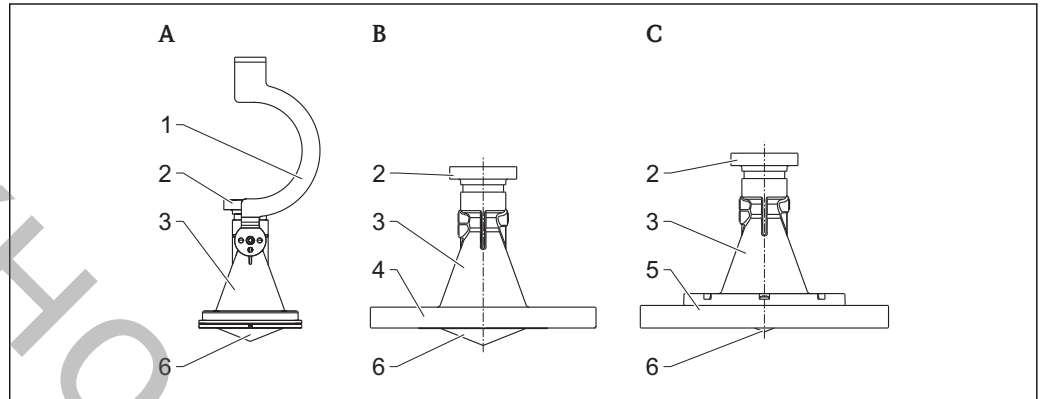

A0018950

- A Standard version with mounting bracket  
 B Horn antenna with slip-on flange  
 C Horn antenna with flange and adapter ring

Pos.	Part	Material
1	Mounting bracket	304 (1.4301)
	Screw	A2
	Nordlock washer	A4
2	Housing adapter	304 (1.4301)
3	Horn	PBT
4	Slip-on flange	PP
5	Flange and adapter ring	PP
	Screw	A2
	Seal	FKM
6	Focusing lense	PP
	Seal	VMQ

FMR57

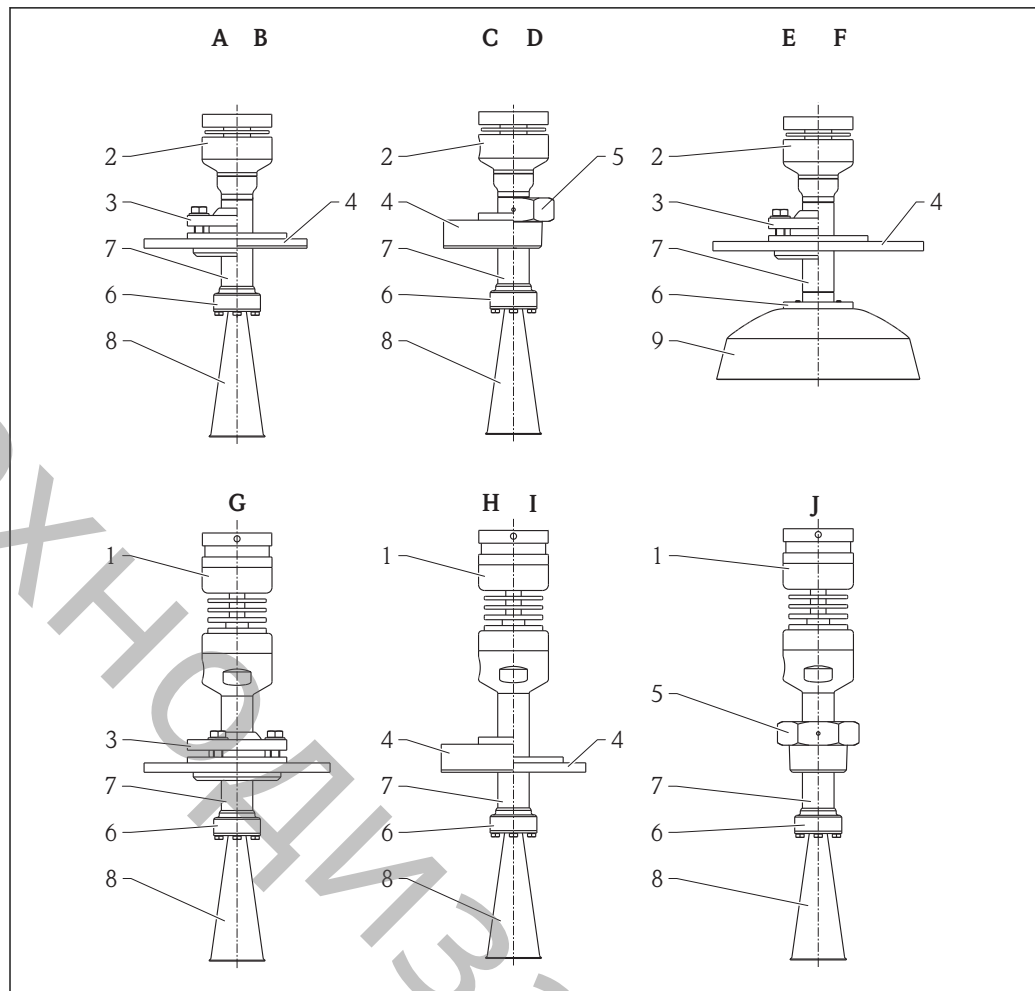

A0018958

- A *Horn standard version with alignment device and UNI flange*
- B *Horn standard version with UNI flange*
- C *Horn standard version with standard flange*
- D *Horn standard version with screw-in adapter*
- E *Paraboloid version with alignment device and UNI flange*
- F *Paraboloid version with UNI flange*
- G *Horn high temperature version with alignment device and UNI flange*
- H *Horn high temperature version with standard flange*
- I *Horn high temperature version with UNI flange*
- J *Horn high temperature version with threaded connection*

Pos.	Part	Material	
1	Housing adapter	316L (1.4404)	
	Temperature reduction	316L (1.4404)	
	Intermediate adapter	316L (1.4404)	
	Purge-air connection	316L (1.4404)	
	Plug	A4	316L (1.4404)
	Adapter (G→NPT)	316L (1.4404)	
2	Housing adapter	316L (1.4404)	
	Plug	A4	316L (1.4404)
	Adapter (G→NPT)	316L (1.4404)	
	Seal	FKM	PTFE (tape)

Pos.	Part	Material	
3	Flange	316L (1.4404)	
	Ball	316L (1.4404)	
	Screws	A2	
	Spring-lock washer	1.4310	
	Clamping flange	316L (1.4404)	
	Adapter	316L (1.4404)	
	Seal (except for version "G")	FKM	
4	Flange	316L (1.4404/1.4435)	
	Adapter	316L (1.4404)	
5	Process connection	316L (1.4404)	
6	Process separating parts	316L (1.4404)	
	Adapter Horn/Parabolic	316L (1.4404)	
7	Tube	316L (1.4404)	
8	Horn	316L (1.4404)	
	Screws	A4	
	Process separating cone	Standard: PEEK	High temperature: PI
	Seal	Standard: FKM	High temperature: Graphite
9	Parabolic reflector	316L (1.4404)	
	Screws	A4	
	Feed	PTFE	
	Seal	FKM	

**Materials: Weather protection cover**

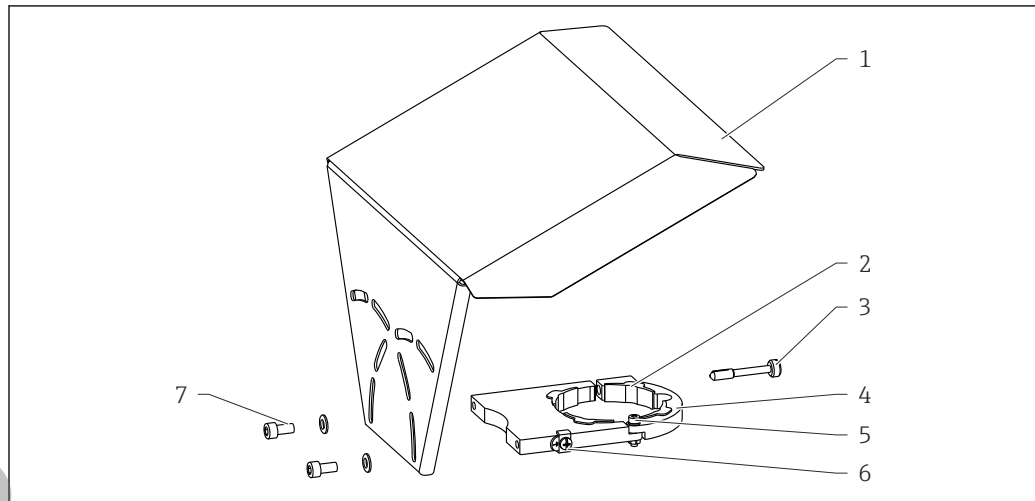

A0015473

No	Part: Material
1	Protection cover: 316L (1.4404)
2	Molded rubber part (4x): EPDM
3	Clamping screw: 316L (1.4404) + carbon fibre
4	Bracket: 316L (1.4404)
5	<ul style="list-style-type: none"> <li>▪ Cheese head screw: A4-70</li> <li>▪ Nut: A4</li> <li>▪ Spring washer: A4</li> </ul>
6	Ground terminal <ul style="list-style-type: none"> <li>▪ Screw: A4</li> <li>▪ Spring washer: A4</li> <li>▪ Clamp: 316L (1.4404)</li> <li>▪ Holder: 316L (1.4404)</li> </ul>
7	<ul style="list-style-type: none"> <li>▪ Washer: A4</li> <li>▪ Cheese head screw: A4-70</li> </ul>

## Operability

### Operating concept

#### Operator-oriented menu structure for user-specific tasks

- Commissioning
- Operation
- Diagnostics
- Expert level

#### Operating languages

- English (contained in every device)
- One additional language as ordered (feature 500 of the product structure)

#### Quick and safe commissioning

- Guided menus ("Make-it-run" wizards) for applications
- Menu guidance with brief explanations of the individual parameter functions

#### Reliable operation

- Standardized operation at the device and in the operating tools
- Data storage device (HistoROM) for process and measuring device data with event logbook available at all times - even if electronics modules are replaced

#### Efficient diagnostics increase measurement reliability

- Remedy information is integrated in plain text
- Diverse simulation options and line recorder functions

### Local operation

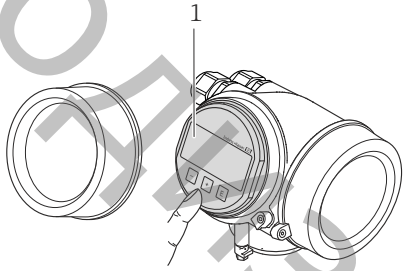
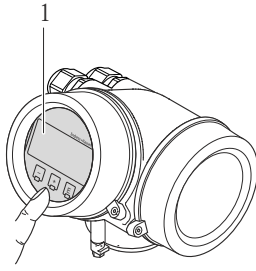
Order code for "Display; Operation", option C "SD02"	Order code for "Display; Operation", option E "SD03"
 <p style="text-align: right; font-size: small;">A0015544</p>	 <p style="text-align: right; font-size: small;">A0015546</p>
1 Operation with pushbuttons	1 Operation with touch control

#### Display elements

- 4-line display
- In the case of order code for "Display; Operation", option E: white background lighting; switches to red in event of device errors
- Format for displaying measured variables and status variables can be individually configured
- Permitted ambient temperature for the display: -20 to +70 °C (-4 to +158 °F)  
The readability of the display may be impaired at temperatures outside the temperature range.

#### Operating elements

- In the case of order code "Display; Operation", Option C: local operation with 3 push buttons (⊖, ⊕, ⊞)
- In the case of order code for "Display; Operation", option E: external operation via touch control; 3 optical keys: ⊖, ⊕, ⊞
- Operating elements also accessible in various hazardous areas

#### Additional functionality

- Data backup function  
The device configuration can be saved in the display module.
- Data comparison function  
The device configuration saved in the display module can be compared to the current device configuration.
- Data transfer function  
The transmitter configuration can be transmitted to another device using the display module.

### Operation with remote display and operating module FHX50

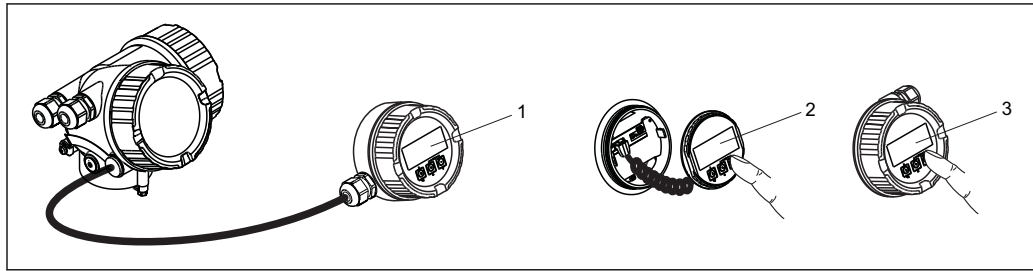

A0013137

31 FHX50 operating options

- 1 Housing of the remote display and operating module FHX50
- 2 Display and operating module SD02, push buttons; cover must be removed
- 3 Display and operating module SD03, optical keys; can be operated through the glass of the cover

### Remote operation

#### Via HART protocol

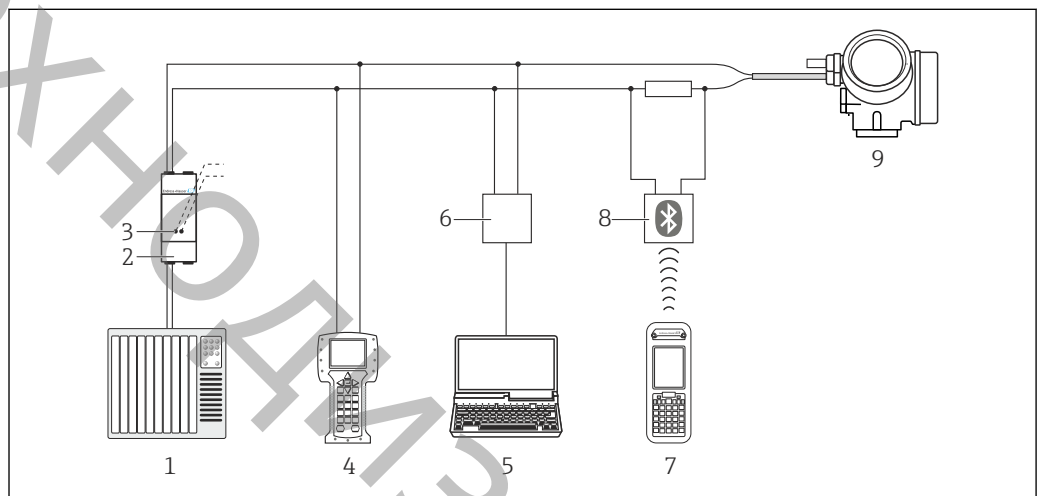

A0013764

32 Options for remote operation via HART protocol

- 1 PLC (programmable logic controller)
- 2 Transmitter power supply unit, e.g. RN221N (with communication resistor)
- 3 Connection for Commubox FXA191, FXA195 and Field Communicator 375, 475
- 4 Field Communicator 475
- 5 Computer with operating tool (e.g. FieldCare, AMS Device Manager, SIMATIC PDM)
- 6 Commubox FXA191 (RS232) or FXA195 (USB)
- 7 Field Xpert SFX350/SFX370
- 8 VIATOR Bluetooth modem with connecting cable
- 9 Transmitter

Via PROFIBUS PA protocol

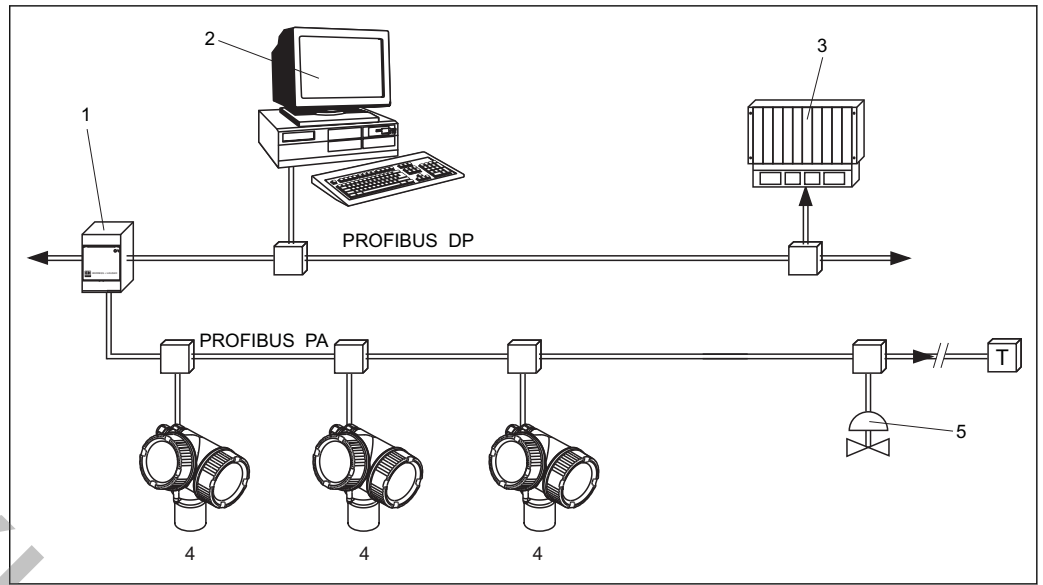

A0015775

- 1 Segment coupler
- 2 Computer with Profiboard/Proficard and operating tool (e.g. FieldCare)
- 3 PLC (Programmable Logic Controller)
- 4 Transmitter
- 5 Additional functions (valves etc.)

Via FOUNDATION Fieldbus

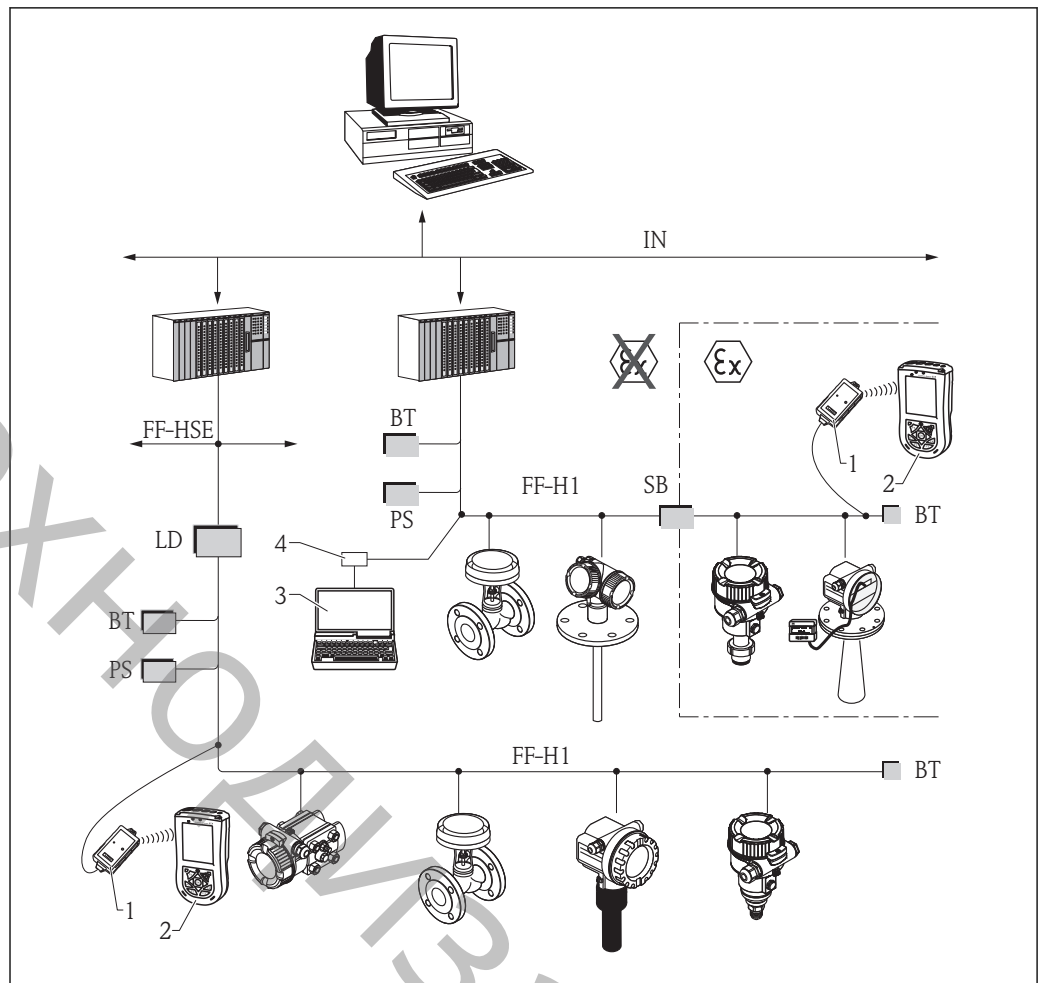

A0017188

33 FOUNDATION Fieldbus system architecture with associated components

- 1 FFblue Bluetooth modem
- 2 Field Xpert SFX350/SFX370
- 3 FieldCare
- 4 NI-FF interface card

IN	Industrial network
FF-HSE	High Speed Ethernet
FF-H1	FOUNDATION Fieldbus-H1
LD	Linking Device FF-HSE/FF-H1
PS	Bus Power Supply
SB	Safety Barrier
BT	Bus Terminator



Via service interface (CDI)

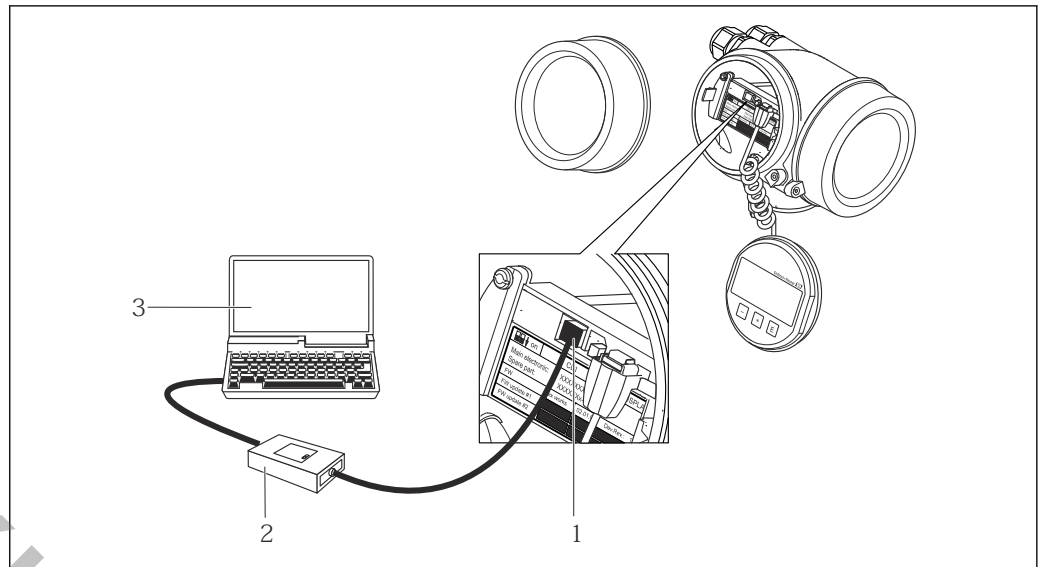

A0014019

- 1 Service interface (CDI) of the measuring device (= Endress+Hauser Common Data Interface)
- 2 Commubox FXA291
- 3 Computer with "FieldCare" operating tool

## System integration via Fieldgate

### Vendor Managed Inventory

By using Fieldgates to interrogate tank or silo levels remotely, suppliers of raw materials can provide their regular customers with information about the current supplies at any time and, for example, account for them in their own production planning. For their part, the Fieldgates monitor the configured level limits and, if required, automatically activate the next supply. The spectrum of options here ranges from a simple purchasing requisition via e-mail through to fully automatic order administration by coupling XML data into the planning systems on both sides.

### Remote maintenance of measuring equipment

Fieldgates not only transfer the current measured values, they also alert the responsible standby personnel, if required, via e-mail or SMS. In the event of an alarm or also when performing routine checks, service technicians can diagnose and configure connected HART devices remotely. All that is required for this is the corresponding HART operating tool (e.g. FieldCare, ...) for the connected device. Fieldgate passes on the information transparently, so that all options for the respective operating software are available remotely. Some on-site service operations can be avoided by using remote diagnosis and remote configuration and all others can at least be better planned and prepared.

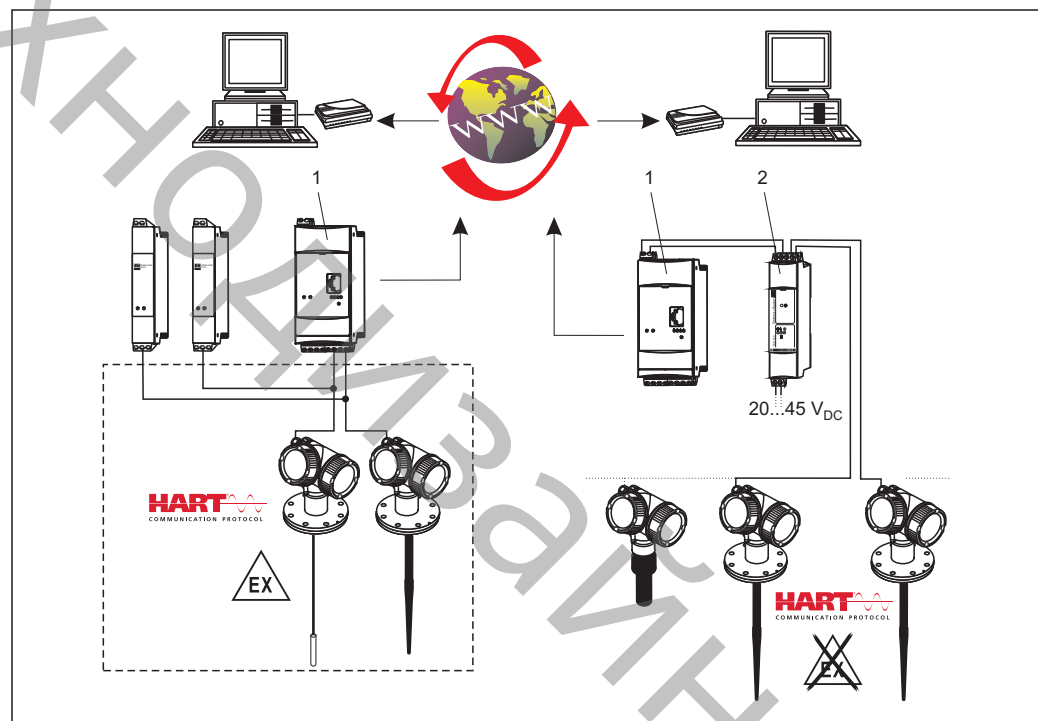



A0011278

34 The complete measuring system consists of devices and:

- 1 Fieldgate FXA520
- 2 Multidrop Connector FXN520

**i** The number of instruments which can be connected in mutidrop mode can be calculated by the "FieldNetCalc" program. A description of this program can be found in Technical Information TI 400F (Multidrop Connector FXN520). The program is available from your Endress+Hauser sales organisation or in the internet at: [www.de.endress.com/Download](http://www.de.endress.com/Download) (text search = "Fieldnetcalc").

## Certificates and approvals

<b>CE mark</b>	<p>The measuring system meets the legal requirements of the applicable EC guidelines. These are listed in the corresponding EC Declaration of Conformity together with the standards applied.</p> <p>Endress+Hauser confirms successful testing of the device by affixing to it the CE mark.</p>
<b>C-Tick symbol</b>	<p>The measuring system meets the EMC requirements of the "Australian Communications and Media Authority (ACMA)".</p>
<b>Ex approval</b>	<ul style="list-style-type: none"> <li>▪ ATEX</li> <li>▪ IEC Ex</li> <li>▪ CSA</li> <li>▪ FM</li> <li>▪ NEPSI</li> <li>▪ KC</li> <li>▪ INMETRO</li> <li>▪ TIIS (in preparation)</li> </ul> <p>Additional safety instructions must be observed for applications in hazardous areas. They are contained in the separate "Safety Instructions" (XA) document, which is included in the scope of delivery. Reference is made to the XA on the nameplate of the device.</p> <p> Details on the available certificates as well as the associated XAs can be found in the <b>Associated documentation</b> chapter in the <b>Safety instructions</b> section: →  92.</p>
<b>Dual seal according to ANSI/ISA 12.27.01</b>	<p>The devices have been designed according to ANSI/ISA 12.27.01 as dual seal devices, allowing the user to waive the use and save the cost of installing external secondary process seals in the conduit as required by the process sealing sections of ANSI/NFPA 70 (NEC) and CSA 22.1 (CEC). These instruments comply with the North-American installation practice and provide a very safe and cost-saving installation for pressurized applications with hazardous fluids.</p> <p>Further information can be found in the Safety Instructions (XA) of the relevant devices.</p>
<b>Functional Safety</b>	<p>Used for level monitoring (MIN, MAX, range) up to SIL 3 (homogeneous or inhomogeneous redundancy), independently assessed by TÜV Rheinland as per IEC 61508. Other information see documentation SD01087F: "Functional Safety Manual".</p>
<b>WHG</b>	<p>WHG approval: Z-65.16-524</p>
<b>Pressure Equipment Directive</b>	<p>The Micropilot is not subject to the scope of the Pressure Equipment Directive 97/23/EC, as it does not have a pressure-bearing housing according to article 1, section 2.1.4 of the directive.</p>
<b>Marine certificate (in preparation)</b>	<p>in preparation</p>
<b>Radio standard EN302729-1/2</b>	<p>The devices Micropilot FMR50, FMR51, FMR52, FMR56 and FMR57 are conform with the LPR (Level Probing Radar) standard EN302729-1/2. The devices are allowed to be used inside or outside of closed bins or tanks in countries of the EU and the EFTA. Precondition is that the country itself already has implemented the directive.</p> <p>At present, the following countries have already implemented the directive:</p> <p>Belgium, Bulgaria, Germany, Denmark, Estonia, France, Greece, Great Britain, Ireland, Iceland, Italy, Liechtenstein, Lithuania, Latvia, Malta, Netherland, Norway, Austria, Poland, Romania, Sweden, Switzerland, Slovakia, Spain, Czech Republic and Cyprus.</p> <p>All countries not mentioned above are at present in the implementation phase.</p> <p>For the use of the devices outside of closed bins or tanks, the following has to be observed:</p> <ol style="list-style-type: none"> <li>1. The installation has to be done by trained personnel.</li> <li>2. The antenna of the device has to be mounted on a fixed place and vertically to the bottom.</li> </ol>

3. The mounting place has to be in a distance of at least 4 km to the mentioned astronomical stations or an appropriate permission has to be issued by the national authority. If the device is mounted at a distance of 4 to 40 km from the stations mentioned, the maximum mounting height is restricted to 15 m (49 ft).

#### Astronomical stations

Country	Name of the station	Geographical latitude	Geographical longitude
Germany	Effelsberg	50°31'32" N	06°53'00" E
Finland	Metsähovi	60°13'04" N	24°23'37" E
	Tuorla	60°24'56" N	24°26'31" E
France	Plateau de Bure	44°38'01" N	05°54'26" E
	Floirac	44°50'10" N	00°31'37" W
United Kingdom	Cambridge	52°09'59" N	00°02'20" E
	Damhall	53°09'22" N	02°32'03" W
	Jodrell Bank	53°14'10" N	02°18'26" W
	Knockin	52°47'24" N	02°59'45" W
	Pickmere	53°17'18" N	02°26'38" W
Italy	Medicina	44°31'14" N	11°38'49" E
	Noto	36°52'34" N	14°59'21" E
	Sardinia	39°29'50" N	09°14'40" E
Poland	Krakow Fort Skala	50°03'18" N	19°49'36" E
Russia	Dmitrov	56°26'00" N	37°27'00" E
	Kalyazin	57°13'22" N	37°54'01" E
	Pushchino	54°49'00" N	37°40'00" E
	Zelenchujskaya	43°49'53" N	41°35'32" E
Sweden	Onsala	57°23'45" N	11°55'35" E
Switzerland	Bleien	47°20'26" N	08°06'44" E
Spain	Yebes	40°31'27" N	03°05'22" W
	Robledo	40°25'38" N	04°14'57" W
Hungary	Penc	47°47'22" N	19°16'53" E



In general the requirements of EN 302729-1/2 have to be taken in consideration.

#### Radio standard EN302372-1/2

The devices Micropilot FMR50, FMR51, FMR52, FMR53, FMR54, FMR56 and FMR57 are conform with the TLPR (Tanks Level Probing Radar) standard EN302372-1/2 and can always be used in closed tanks or bins. For installation, points a to f in Annex B of EN302372-1 have to be taken into account.

#### FCC / Industry Canada

This device complies with Part 15 of the FCC rules. Operation is subject to the following two conditions: (1) This device may not cause harmful interference, and (2) this device must accept any interference received, including interference that may cause undesired operation.

#### Canada CNR-Gen Section 7.1.3

This device complies with Industry Canada licence-exempt RSS standard(s). Operation is subject to the following two conditions: (1) This device may not interference, and (2) this device must accept any interference, including interference that may cause undesired operation of the device.

*Le présent appareil est conforme aux CNR d'Industrie Canada applicables aux appareils radio exempts de licence. L'exploitation est autorisée aux deux conditions suivantes : (1) l'appareil ne doit pas produire de brouillage, et (2) l'utilisateur de l'appareil doit accepter tout brouillage radioélectrique subi, même si le brouillage est susceptible d'en compromettre le fonctionnement.*

[Any] changes or modifications not expressly approved by the party responsible for compliance could void the user's authority to operate the equipment.

In addition, the devices FMR50<sup>7)</sup>, FMR51<sup>8)</sup>, FMR52<sup>9)</sup>, FMR56 and FMR57 are compliant with the LPR (Level probe radar) regulation also for free space applications according to the FCC Code of Federal Regulations, CFR 47, Part 15, Sections 15.205, 15.207, 15.209, 15.256 for antenna sizes bigger than 50 mm (2.0 in)<sup>10)</sup>. For these applications the devices must be professionally installed in a downward operating position. In addition, the devices are not allowed to be mounted in a zone of 4 km around RAS stations and within a radius of 40 km around RAS stations the maximum operation height of devices is 15 m (49 ft) above ground.

**Japanese radio approval**

The devices FMR50, FMR51, FMR52, FMR54 and FMR57 comply with the Japanese Radio Law, Article 6, Section 1(1).

**CRN approval**

Some device versions have a CRN approval. Devices are CRN approved if the following two conditions are met:

- The device has a CSA approval (Product structure: Feature 010 "Approval")
- The device has a CRN approved process connection according to the following table.

Feature 100 of the product structure	Process connection
AGJ	NPS 3" Cl.150 RF, 316/316L
AHJ	NPS 4" Cl.150 RF, 316/316L
RGJ	Thread ANSI MNPT1-1/2, 316L
RVJ	Thread EN10226 R1-1/2, 316L
XWG	UNI slip on flange 3"/DN80/80, PP
XZG	UNI slip on flange 4"/DN100/100, PP
XOG	UNI slip on flange 6"/DN150/150, PP

-  ■ Process connections without CRN approval are not included in this table.
- Refer to the product structure to see which process connections are available for a specific device type.
- CRN approved devices are marked with the registration number OF15872.5C on the nameplate.

 For device versions listed in the table below, the maximum allowed pressure is reduced if they have a CRN approval. For device versions not listed in the table below the pressure range as indicated in the "Process" chapter → 49 is not affected by the CRN approval.

Product	Antenna <sup>1)</sup>	Prozessanschluss <sup>2)</sup>	Dichtung <sup>3)</sup>	max. pressure
FMR50/FMR56	BN: Horn 80mm/3"	XWG: UNI slip-on flange 3"		1.6 bar (23.2 psi)
		XZG: UNI slip-on flange 4"		1.5 bar (21.75 psi)
		XOG: UNI slip-on flange 6"		1.5 bar (21.75 psi)
	BR: Horn 100mm/4"	XZG: UNI slip-on flange 4"		12 bar (17.4 psi)
		XOG: UNI slip-on flange 6"		1.8 bar (26.1 psi)

- 1) Feature 070 of the product structure
- 2) Feature 100 of the product structure
- 3) Feature 090 of the product structure

**Track record**

FMR5x is the upgrade model of the corresponding FMR2xx series.

7) Except of FMR50-#####BM\* (Horn 40mm/1-1/2", PVDF encapsulated)  
 8) Except for FMR51-#####BA\* (Horn 40mm/1-1/2") and FMR51-#####BB\* (Horn 50mm/2")  
 9) Except for FMR52-#####BO\* (Horn 50mm/2", flush mount)  
 10)

## Test, Certificate

Feature 580 "Test, Certificate"	Designation	Available for
JD	3.1 Material certificate, pressurized parts, EN10204-3.1 inspection certificate	FMR57
KV	Conformity to ASME B31.3: The dimensions, materials of construction, pressure / temperature ratings and identification markings of the device comply with the requirements of ASME B31.3	FMR57

ТЕХНОДИЗАЙН-М

**Other standards and guidelines**

- EN 60529  
Degrees of protection by housing (IP code)
- EN 61010-1  
Protection Measures for Electrical Equipment for Measurement, Control, Regulation and Laboratory Procedures.
- IEC/EN 61326  
"Emission in accordance with Class A requirements". Electromagnetic compatibility (EMC requirements)
- NAMUR NE 21  
Electromagnetic compatibility (EMC) of industrial process and laboratory control equipment.
- NAMUR NE 43  
Standardization of the signal level for the breakdown information of digital transmitters with analog output signal.
- NAMUR NE 53  
Software of field devices and signal-processing devices with digital electronics
- NAMUR NE 107  
Status classification as per NE107
- NAMUR NE 131  
Requirements for field devices for standard applications
- IEC61508  
Functional safety of electrical/electronic/programmable electronic safety-related systems

ТЕХНОДИЗАЙН-М

## Ordering information

### Ordering information

Detailed ordering information is available from the following sources:

- In the Product Configurator on the Endress+Hauser web site: [www.endress.com](http://www.endress.com) → Choose your country → Products → Select measuring technology, software or components → Select product (picklists: measurement method, product family etc.) → Device support (right-hand column): Configure the selected product → The Product Configurator for the selected product is opened.
- From your Endress+Hauser Sales Center: [www.addresses.endress.com](http://www.addresses.endress.com)



#### **Product Configurator - the tool for individual product configuration**

- Up-to-the-minute configuration data
- Depending on the device: Direct input of measuring point-specific information such as measuring range or operating language
- Automatic verification of exclusion criteria
- Automatic creation of the order code and its breakdown in PDF or Excel output format
- Ability to order directly in the Endress+Hauser Online Shop

ТЕХНОДИЗАЙН-М



**3-point linearity protocol**

**i** The following notes must be taken into account if option F3 ("3 point linearity protocol") has been selected in feature 550 ("Calibration").

The 3 points of the linearity protocol are defined as follows:

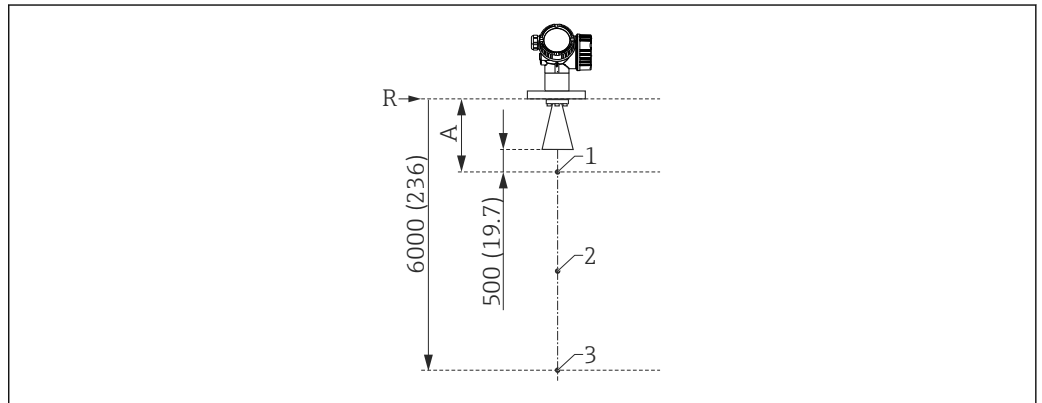

**35** Points of the 3-point linearity protocol; Dimensions: mm (in)

- A Distance from reference point R to first measuring point
- R Reference point of the measurement
- 1 First measuring point
- 2 Second measuring point (centrally between first and third measuring point)
- 3 Third measuring point

Measuring point	Position
1 <sup>st</sup> measuring point	<ul style="list-style-type: none"> <li>▪ At the distance A from the reference point</li> <li>▪ A = antenne length + antenna extension (if present) + 500 mm (19.7 in)</li> <li>▪ Minimum distance: <math>A_{min} = 1000</math> mm (39.4 in)</li> </ul>
2 <sup>nd</sup> measuring point	centrally between 1 <sup>st</sup> and 3 <sup>rd</sup> measuring point
3 <sup>rd</sup> measuring point	6000 mm (236 in) below the reference point, R

**i** The position of the measuring points may vary by  $\pm 1$  cm ( $\pm 0.04$  in).

**i** The linearity is checked under reference conditions.

**5-point linearity protocol**

**i** The following notes must be taken into account if option F4 ("5 point linearity protocol") has been selected in feature 550 ("Calibration").

The five points of the linearity protocol are evenly distributed across the measuring range (0% to 100%). In order to define the measuring range, **Empty calibration** (E) and **Full calibration** (F) have to be specified <sup>11)</sup>.

The following restrictions have to be taken into account when defining E and F:

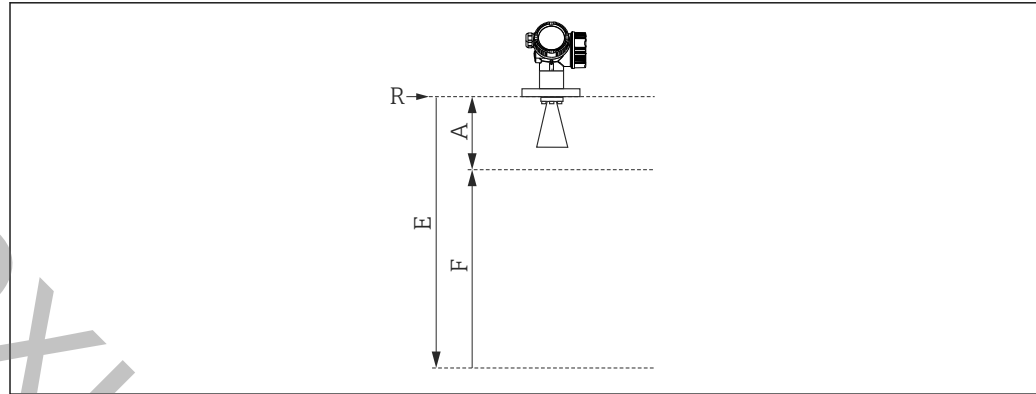

A0017983

Device version	Minimum distance between reference point (R) and 100% level	Minimum span	Maximum value for "Empty calibration"
FMR56/FMR57 Without antenna extension	$A \geq \text{antenna length} + 600 \text{ mm (24 in)}^1$	$F \geq 400 \text{ mm (16 in)}$	$E \leq 20 \text{ m (66 ft)}$
FMR57 with antenna extension <sup>2)</sup>	$A \geq \text{antenna length} + \text{antenna extension} + 600 \text{ mm (24 in)}^3$		

- 1) Minimum value for FMR57: 861 mm (16 in)  
 2) Feature 610 "Accessory Mounted", option OP or OT  
 3) Minimum value: 861 mm (16 in)

**i** The linearity is checked under reference conditions.

**i** The selected values of **Empty calibration** and **Full calibration** are only used to record the linearity protocol and are reset to their probe specific default values thereafter. If values different from the default are required, they must be ordered as a customized parametrization → 83.

11) If E and F are not specified, probe dependent default values will be used instead.

**Customized parametrization** If the option IJ "Customized parametrization HART", IK "Customized parametrization PA" or IL "Customized parametrization FF" has been selected in feature 570 "Service", customer specific presettings can be selected for the following parameters:

Parameter	Communication	Selection list / range of values
Setup → Distance unit	<ul style="list-style-type: none"> <li>■ HART</li> <li>■ PA</li> <li>■ FF</li> </ul>	<ul style="list-style-type: none"> <li>■ in</li> <li>■ mm</li> </ul>
Setup → Empty calibration	<ul style="list-style-type: none"> <li>■ HART</li> <li>■ PA</li> <li>■ FF</li> </ul>	max. 70 m (230 ft)
Setup → Full calibration	<ul style="list-style-type: none"> <li>■ HART</li> <li>■ PA</li> <li>■ FF</li> </ul>	max. < 70 m (230 ft)
Setup → Adv. Setup → Current output 1/2 → Damping	HART	0 to 999.9 s
Setup → Adv. Setup → Current output 1/2 → Failure mode	HART	<ul style="list-style-type: none"> <li>■ Min</li> <li>■ Max</li> <li>■ Last valid value</li> </ul>
Setup → Adv. Setup → Current output 1/2 → Burst mode	HART	<ul style="list-style-type: none"> <li>■ Off</li> <li>■ On</li> </ul>

**Services**



The following services can be selected via the product structure in the Product Configurator <sup>12)</sup>:

- PWIS free (PWIS: paint wetting impairment substances)
- Customized parametrization HART → 83
- Customized parametrization PA → 83
- Customized parametrization FF → 83
- Without tooling DVD (FieldCare)

12) Feature 570 of the product structure

## Accessories

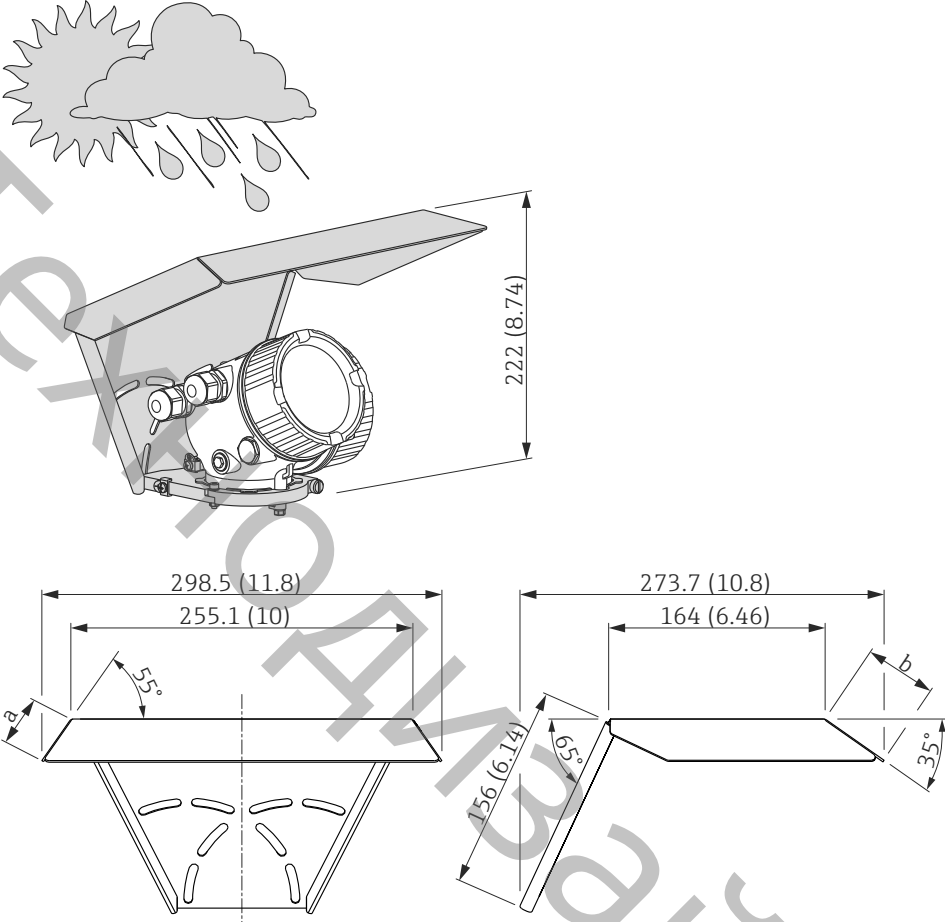
### Device-specific accessories Weather protection cover

Accessory	Description
Weather protection cover	 <p data-bbox="1380 929 1436 952">A0015466</p> <p data-bbox="1380 1344 1436 1366">A0015472</p> <p data-bbox="327 1366 837 1400">  36 Weather protection cover; Dimensions: mm (in)         </p> <p data-bbox="327 1406 534 1440"> <i>a</i> 37,8 mm (1,5 in)         </p> <p data-bbox="327 1435 518 1469"> <i>b</i> 54 mm (2,1 in)         </p> <p data-bbox="327 1489 1404 1570">  The weather protection cover can be ordered together with the device (product structure, feature 620 "Accessory Enclosed", option PB "Weather Protection Cover"). Alternatively, it can be separately ordered as an accessory; order code 71162242.         </p>

Variable flange seal for FMR50/FMR56

Accessory	Description		
Variable flange seal for FMR50/FMR56	<p>                         1 UNI slip-on flange                          2 Variable flange seal                          3 Nozzle                     </p> <p>  The material and process conditions of the adjustable flange seal must fit the process properties (temperature, pressure, resistance).                     </p> <p>  For FMR56: The variable flange seal can also be ordered together with the device (product structure: feature 620 "Accessory Enclosed", options PL, PM, PN, PO, PQ, PR).                     </p>		
<b>Technical data: DN/JIS version</b>			
Order code	71074263	71074264	71074265
Compatible with	DN80 PN10/40	DN100 PN10/16	<ul style="list-style-type: none"> <li>▪ DN150 PN10/16</li> <li>▪ JIS 10K 150A</li> </ul>
Length of screws	100 mm (3.9 in)	100 mm (3.9 in)	110 mm (4.3 in)
Size of screws	M14	M14	M18
Material	EPDM		
Process pressure	-0.1 to 0.1 bar (-1.45 to 1.45 psi)		
Process temperature	-40 to +80 °C (-40 to +176 °F)		
D	142 mm (5.59 in)	162 mm (6.38 in)	218 mm (8.58 in)
d	89 mm (3.5 in)	115 mm (4.53 in)	169 mm (6.65 in)
h	22 mm (0.87 in)	23.5 mm (0.93 in)	26.5 mm (1.04 in)
h <sub>min</sub>	14 mm (0.55 in)	14 mm (0.55 in)	14 mm (0.55 in)
h <sub>max</sub>	30 mm (1.18 in)	33 mm (1.3 in)	39 mm (1.45 in)

Accessory	Description		
	Technical data: ASME/JIS version		
Order code	71249070	71249072	71249073
Compatible with	<ul style="list-style-type: none"> <li>▪ ASME 3" 150lbs</li> <li>▪ JIS 80A 10K</li> </ul>	ASME 4" 150lbs	ASME 6" 150lbs
Length of screws	100 mm (3.9 in)	100 mm (3.9 in)	110 mm (4.3 in)
Empfohlene Schraubengröße	M14	M14	M18
Material	EPDM		
Process pressure	-0.1 to 0.1 bar (-1.45 to 1.45 psi)		
Process temperature	-40 to +80 °C (-40 to +176 °F)		
D	133 mm (5.2 in)	171 mm (6.7 in)	219 mm (8.6 in)
d	89 mm (3.5 in)	115 mm (4.53 in)	168 mm (6.6 in)
h	22 mm (0.87 in)	23.5 mm (0.93 in)	26.5 mm (1.04 in)
h <sub>min</sub>	14 mm (0.55 in)	14 mm (0.55 in)	14 mm (0.55 in)
h <sub>max</sub>	30 mm (1.18 in)	33 mm (1.3 in)	39 mm (1.45 in)



#### Mounting bracket for wall or ceiling mounting of FMR50/FMR56

Accessory	Description
Mounting bracket for wall or ceiling mounting of FMR50/FMR56	<p><b>A</b></p> <p><b>B</b></p> <p> </p> <p> </p> <p> </p> <p>A0017746</p> <p> <b>37</b> Mounting bracket for FMR50/FMR56 with horn antenna  <b>A</b> Mounting at ceiling  <b>B</b> Mounting at wall </p> <ul style="list-style-type: none"> <li>▪ <b>Material:</b> <ul style="list-style-type: none"> <li>- Mounting bracket: 304 (1.4301)</li> <li>- Screws: A2</li> <li>- Nordlock washer: A4</li> </ul> </li> <li>▪ <b>Order code:</b> 71162776</li> </ul>

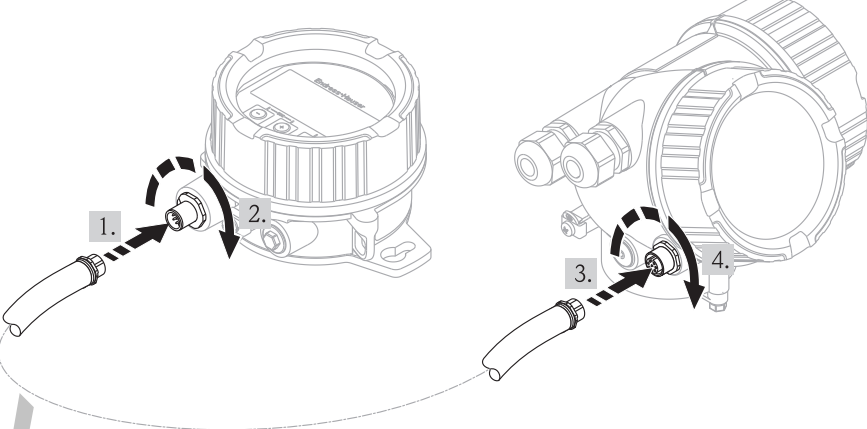
Remote display FHX50

Accessory	Description
<p>Remote display FHX50</p>	<div style="text-align: center;">  </div> <p style="text-align: right; font-size: small;">A0019128</p> <ul style="list-style-type: none"> <li>▪ Material:             <ul style="list-style-type: none"> <li>- Plastics PBT</li> <li>- 316L</li> </ul> </li> <li>▪ Ingress protection: IP68 / NEMA 6P and IP66 / NEMA 4x</li> <li>▪ Suitable for the display modules:             <ul style="list-style-type: none"> <li>- SD02 (push buttons)</li> <li>- SD03 (touch control)</li> </ul> </li> <li>▪ Connection cable:             <ul style="list-style-type: none"> <li>- Cable with M12 plug; supplied with the FHX50; up to 30 m (98 ft)</li> <li>- Customer supplied standard cable; up to 60 m (196 ft)</li> </ul> </li> <li>▪ Ambient temperature: -40 to 80 °C (-40 to 176 °F)</li> </ul> <p> <span style="border: 1px solid black; padding: 2px;">i</span> ▪ If the remote display is to be used, the device must be ordered in the version "Prepared for display FHX50" (feature 030, option L or M). For the FHX50, on the other hand, the option A: "Prepared for display FHX50" has to be selected in feature 050: "Option Measurement Device".         </p> <p> <span style="border: 1px solid black; padding: 2px;">i</span> ▪ If a device has not been ordered in the version "Prepared for display FHX50", but is nevertheless to be equipped with an FHX50, it is essential to select the option B: "Not prepared for display FHX50" in feature 050: "Option Measurement Device" of the FHX50. In this case, a retrofit kit, needed to prepare the device for the remote display, is supplied together with the FHX50.         </p> <p> <span style="border: 1px solid black; padding: 2px;">i</span> For transmitters with approval, application of the FHX50 may be restricted. A device may only be retrofitted with the FHX50 if option L or M ("Prepared for FHX50") is quoted under <i>Basic specifications</i>, position 4 "Display, operation" in the associated Safety Instructions (XA). In addition to this, observe the Safety Instructions (XA) of the FHX50.         </p> <p> <span style="border: 1px solid black; padding: 2px;">i</span> Do not retrofit transmitters with:             <ul style="list-style-type: none"> <li>▪ approval for use in areas with combustible dusts (Dust-Ex approval)</li> <li>▪ type of protection Ex nA</li> </ul> </p> <p> <span style="border: 1px solid black; padding: 2px;">i</span> For details refer to the document SD01007F.         </p>

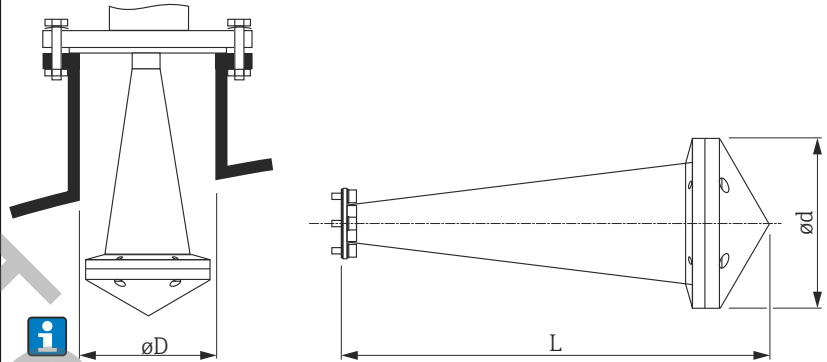
## Horn protection for horn antenna

Accessory	Description
Horn protection for 80 mm (3 in) or 100 mm (4 in) horn antenna	 <p>For details please refer to the Mounting Instructions SD01084F.</p> <p><b>Process conditions</b></p> <ul style="list-style-type: none"> <li>Maximum vessel pressure: 0.5 bar (7.252 psi)</li> <li>Maximum process temperature: 130 °C (266 °F)</li> </ul> <p> Danger of explosion Avoid electrostatic charging of the horn protection.</p> <p style="text-align: right;">A0019143</p>

## Horn protection for FMR57

Antenna <sup>1)</sup>	Order code of horn protection	Dimensions		
		Ød	L	ØD
BC: Horn 80mm/3"	71105890	96 mm (3.78 in)	238 mm (9.4 in)	≥ DN100
BD: Horn 100mm/4"	71105889	116 mm (4.57 in)	450 mm (17.7 in)	≥ DN150

1) Feature 070 of the product structure





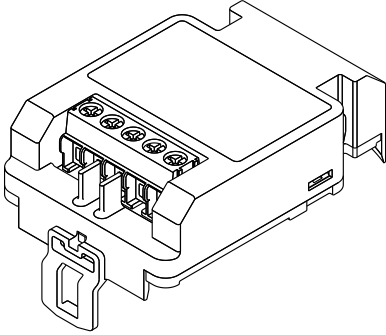

 The horn protection can also be ordered together with the device. Product structure: Feature 610 "Accessory Mounted", option OW "Horn protection, PTFE".



Overvoltage protection

Accessory	Description
Overvoltage protection for 2-wire-devices OVP10 (1 channel) OVP20 (2 channel)	<div style="text-align: right; font-size: small;">A0021734</div>  <p><b>Technical data</b></p> <ul style="list-style-type: none"> <li>▪ Resistance per channel: <math>2 * 0.5 \Omega_{max}</math></li> <li>▪ Threshold DC voltage: 400 to 700 V</li> <li>▪ Threshold impulse voltage: &lt; 800 V</li> <li>▪ Capacitance at 1 MHz: &lt; 1.5 pF</li> <li>▪ Nominal arrest impulse voltage (8/20 <math>\mu</math>s): 10 kA</li> <li>▪ Suited for wire cross-sections: 0.2 to 2.5 mm<sup>2</sup> (24 to 14 AWG)</li> </ul> <p><b>i</b> <b>Ordering with device</b>                      The overvoltage protection module is preferably ordered with the device. See product structure, feature 610 "Accessory mounted", option NA "Overvoltage protection". Separate ordering of the module is only necessary if a device is to be retrofitted with the overvoltage protection.</p> <p><b>i</b> <b>Order code for retrofitting</b></p> <ul style="list-style-type: none"> <li>▪ For 1-channel devices (feature 020, option A)                          OVP10: 71128617</li> <li>▪ For 2-channel devices (feature 020, option B, C, E or G)                          OVP20 : 71128619</li> </ul> <p><b>Housing lid for retrofitting</b>                      In order to keep the necessary safety distances, the housing lid needs to be replaced if the device is retrofitted with the overvoltage protection. Depending on the housing type, the order code of the suitable lid is as follows:</p> <ul style="list-style-type: none"> <li>▪ GT18 housing: Lid 71185516</li> <li>▪ GT19 housing: Lid 71185518</li> <li>▪ GT20 housing: Lid 71185516</li> </ul> <p><b>i</b> <b>Restrictions for retrofitting</b>                      Depending on the approval of the transmitter the usage of the OVP module may be restricted. A device may only be retrofitted with an OVP module if the option NA (overvoltage protection) is quoted under <i>Optional Specifications</i> in the Safety Instructions (XA) pertaining to the device.</p> <p><b>i</b> For details refer to SD01090F.</p>

## Communication-specific accessories



Accessory	Description
Commubox FXA195 HART	For intrinsically safe HART communication with FieldCare via the USB interface.  For details refer to Technical Information TI00404F
Commubox FXA291	Connects Endress+Hauser field devices with CDI interface (= Endress+Hauser Common Data Interface) to the USB interface of a computer. Order code: 51516983  For details refer to Technical Information TI00405C
HART Loop Converter HMX50	Evaluates the dynamic HART variables and converts them to analog current signals or limit values. Order code: 71063562  For details refer to Technical Information TI00429F and Operating Instructions BA00371F
WirelessHART Adapter SWA70	Connects field devices to a WirelessHART network. The WirelessHART adapter can be mounted directly at a HART device and is easily integrated into an existing HART network. It ensures safe data transmission and can be operated in parallel with other wireless networks.  For details refer to Operating Instructions BA00061S
Fieldgate FXA320	Gateway for remote monitoring of connected 4-20mA measuring devices via web browser.  For details refer to Technical Information TI00025S and Operating Instructions BA00053S
Fieldgate FXA520	Gateway for remote diagnosis and parametrization of connected HART measuring devices via web browser.  For details refer to Technical Information TI00025S and Operating Instructions BA00051S
Field Xpert SFX350	Field Xpert SFX350 is a mobile computer for commissioning and maintenance. It enables efficient device configuration and diagnostics for HART and FOUNDATION fieldbus devices in the <b>non-Ex area</b> .  For details, see Operating Instructions BA01202S

Accessory	Description
Field Xpert SFX370	Field Xpert SFX370 is a mobile computer for commissioning and maintenance. It enables efficient device configuration and diagnostics for HART and FOUNDATION fieldbus devices in the <b>non-Ex area</b> and the <b>Ex area</b> .  For details, see Operating Instructions BA01202S

**Service-specific accessories**

Accessory	Description
FieldCare	Endress+Hauser's FDT-based Plant Asset Management tool. Helps to configure and maintain all field devices of your plant. By supplying status information it also supports the diagnosis of the devices.  For details refer to Operating Instructions BA00027S and BA00059S.

**System components**

Accessory	Description
Graphic Data Manager Memograph M	The graphic data manager Memograph M provides information on all the relevant process variables. Measured values are recorded correctly, limit values are monitored and measuring points analyzed. The data are stored in the 256 MB internal memory and also on an SD card or USB stick.  For details refer to Technical Information TI00133R and Operating Instructions BA00247R
RN221N	Active barrier with power supply for safe separation of 4 to 20 mA current circuits. Provides bi-directional HART transmission.  For details refer to Technical Information TI00073R and Operating Instructions BA00202R
RNS221	Transmitter supply for 2-wire sensors or transmitters exclusively for non-Ex areas. Provides bi-directional communication using the HART communication sockets.  For details refer to Technical Information TI00081R and Operating Instructions KA00110R

## Documentation



The following document types are available:

- On the CD supplied with the device
- In the Download Area of the Endress+Hauser Internet site: [www.endress.com](http://www.endress.com) → Download

### Standard documentation

#### Micropilot FMR56, FMR57

Correlation of documentations to the device:

Device	Power supply, output	Communication	Document type	Document code
FMR56, FMR57	A, B, C, K, L	HART	Operating Instructions	BA01048F/00/EN
			Brief Operating Instructions	KA01102F/00/EN
			Description of Device Parameters	GP01014F/00/EN
	G	PROFIBUS PA	Operating Instructions	BA01127F/00/EN
			Brief Operating Instructions	KA01131F/00/EN
			Description of Device Parameters	GP01018F/00/EN
E	FOUNDATION Fieldbus	Operating Instructions	BA01123F/00/EN	
		Brief Operating Instructions	KA01127F/00/EN	
		Description of Device Parameters	GP01017F/00/EN	

### Supplementary documentation

Device	Document type	Document code
Fieldgate FXA520	Technical Information	TI369F/00/EN
Tank Side Monitor NRF590	Technical Information	TI402F/00/EN
	Operating Instructions	BA256F/00/EN
	Description of Device Parameters	BA257F/00/EN

### Safety Instructions (XA)

Depending on the approval, the following Safety Instructions (XA) are supplied with the device. They are an integral part of the Operating Instructions.

Feature 010	Approval	Available for	Feature 020 "Power Supply; Output"				
			A <sup>1)</sup>	B <sup>2)</sup>	C <sup>3)</sup>	E <sup>4)/G<sup>5)</sup></sup>	K <sup>6)/L<sup>7)</sup></sup>
BA	ATEX: II 1 G Ex ia IIC T6-T1 Ga	<ul style="list-style-type: none"> <li>▪ FMR56</li> <li>▪ FMR57</li> </ul>	XA00677F	XA01224F	XA001225	XA00685F	-
BB	ATEX: II 1/2 G Ex ia IIC T6-T1 Ga/Gb	<ul style="list-style-type: none"> <li>▪ FMR56</li> <li>▪ FMR57</li> </ul>	XA00677F	XA01224F	XA001225	XA00685F	-
BC	ATEX: II 1/2 G Ex d [ia] IIC T6-T1 Ga/Gb	<ul style="list-style-type: none"> <li>▪ FMR56</li> <li>▪ FMR57</li> </ul>	XA00680F	XA00680F	XA01232F	XA00688F	XA01233F
BD	ATEX: II 1/2/3 G Ex ic [ia Ga] IIC T6-T1 Ga/Gb/Gc	FMR57	XA00678F	XA01226F	XA01227F	XA00686F	XA01228F
BE	ATEX: II 1 D Ex ta IIIC T <sub>500</sub> xx°C Da	<ul style="list-style-type: none"> <li>▪ FMR56</li> <li>▪ FMR57</li> </ul>	XA00682F	XA00682F	XA00682F	XA00690F	XA00682F
BF	ATEX: II 1/2 D Ex ta IIIC Txx°C Da/Db	<ul style="list-style-type: none"> <li>▪ FMR56</li> <li>▪ FMR57</li> </ul>	XA00682F	XA00682F	XA00682F	XA00690F	XA00682F
BG	ATEX: II 3 G Ex nA IIC T6-T1 Gc	<ul style="list-style-type: none"> <li>▪ FMR56</li> <li>▪ FMR57</li> </ul>	XA00679F	XA01229F	XA01230F	XA00687F	XA01231F
BH	ATEX: II 3 G Ex ic IIC T6-T1 Gc	<ul style="list-style-type: none"> <li>▪ FMR56</li> <li>▪ FMR57</li> </ul>	XA00679F	XA01229F	XA01230F	XA00687F	XA01231F

Feature 010	Approval	Available for	Feature 020 "Power Supply; Output"				
			A <sup>1)</sup>	B <sup>2)</sup>	C <sup>3)</sup>	E <sup>4)/G<sup>5)</sup></sup>	K <sup>6)/L<sup>7)</sup></sup>
BL	ATEX: II 1/2/3 G Ex nA [ia Ga] IIC T6-T1 Ga/Gb/Gc	FMR57	XA00678F	XA01226F	XA01227F	XA00686F	XA01228F
B2	ATEX: II 1/2 G Ex ia IIC T6-T1 Ga/Gb ATEX: II 1/2 D Ex ia IIIC Txx°C Da/Db	<ul style="list-style-type: none"> <li>▪ FMR56</li> <li>▪ FMR57</li> </ul>	XA00683F	XA00683F	XA01235F	XA00691F	-
B3	ATEX: II 1/2 G Ex d [ia] IIC T6-T1 Ga/Gb ATEX: II 1/2 D Ex ta IIIC Txx°C Da/Db	<ul style="list-style-type: none"> <li>▪ FMR56</li> <li>▪ FMR57</li> </ul>	XA00684F	XA00684F	XA00684F	XA00692F	XA01236F
CD	CSA C/US DIP Cl.II,III Div.1 Gr.E-G	<ul style="list-style-type: none"> <li>▪ FMR56</li> <li>▪ FMR57</li> </ul>	XA01113F	XA01113F	XA01113F	XA01115F	XA01113F
C2	CSA C/US IS Cl.I,II,III Div.1 Gr.A-G, NI Cl.1 Div.2, Ex ia	<ul style="list-style-type: none"> <li>▪ FMR56</li> <li>▪ FMR57</li> </ul>	XA01112F	XA01112F	XA01112F	XA01114F	-
C3	CSA C/US XP Cl.I,II,III Div.1 Gr.A-G, NI Cl.1 Div.2, Ex d	<ul style="list-style-type: none"> <li>▪ FMR56</li> <li>▪ FMR57</li> </ul>	XA01113F	XA01113F	XA01113F	XA01115F	XA01113F
FA	FM IS Cl.I Div.1 Gr.A-D	FMR56	XA01116F	XA01116F	XA01116F	XA01118F	-
FB	FM IS Cl.I,II,III Div.1 Gr.A-G, AEx ia, NI Cl.1 Div.2	<ul style="list-style-type: none"> <li>▪ FMR56</li> <li>▪ FMR57</li> </ul>	XA01116F	XA01116F	XA01116F	XA01118F	-
FC	FM XP Cl.I Div.1 Gr.A-D	FMR56	XA01117F	XA01117F	XA01117F	XA01119F	XA01117F
FD	FM XP Cl.I,II,III Div.1 Gr.A-G, AEx d, NI Cl.1 Div.2	<ul style="list-style-type: none"> <li>▪ FMR56</li> <li>▪ FMR57</li> </ul>	XA01117F	XA01117F	XA01117F	XA01119F	XA01117F
FE	FM DIP Cl.II,III Div.1 Gr.E-G	<ul style="list-style-type: none"> <li>▪ FMR56</li> <li>▪ FMR57</li> </ul>	XA01117F	XA01117F	XA01117F	XA01119F	XA01117F
IA	IECEEx: Ex ia IIC T6-T1 Ga	<ul style="list-style-type: none"> <li>▪ FMR56</li> <li>▪ FMR57</li> </ul>	XA00677F	XA01224F	XA001225	XA00685F	-
IB	IECEEx: Ex ia IIC T6-T1 Ga/Gb	<ul style="list-style-type: none"> <li>▪ FMR56</li> <li>▪ FMR57</li> </ul>	XA00677F	XA01224F	XA001225	XA00685F	-
IC	IECEEx: Ex d [ia] IIC T6-T1 Ga/Gb	<ul style="list-style-type: none"> <li>▪ FMR56</li> <li>▪ FMR57</li> </ul>	XA00680F	XA00680F	XA01232F	XA00688F	XA01233F
ID	IECEEx: Ex ic [ia Ga] IIC T6-T1 Ga/Gb/Gc	FMR57	XA00678F	XA01226F	XA01227F	XA00686F	XA01228F
IE	IECEEx: Ex ta IIIC T <sub>500</sub> xx°C Da	<ul style="list-style-type: none"> <li>▪ FMR56</li> <li>▪ FMR57</li> </ul>	XA00682F	XA00682F	XA00682F	XA00690F	XA00682F
IF	IECEEx: Ex ta IIIC Txx°C Da/Db	<ul style="list-style-type: none"> <li>▪ FMR56</li> <li>▪ FMR57</li> </ul>	XA00682F	XA00682F	XA00682F	XA00690F	XA00682F
IG	IECEEx: Ex nA IIC T6-T1 Gc	<ul style="list-style-type: none"> <li>▪ FMR56</li> <li>▪ FMR57</li> </ul>	XA00679F	XA01229F	XA01230F	XA00687F	XA01231F
IH	IECEEx: Ex ic IIC T6-T1 Gc	<ul style="list-style-type: none"> <li>▪ FMR56</li> <li>▪ FMR57</li> </ul>	XA00679F	XA01229F	XA01230F	XA00687F	XA01231F
IL	IECEEx: Ex nA [ia Ga] IIC T6-T1 Ga/Gb/Gc	FMR57	XA00678F	XA01226F	XA01227F	XA00686F	XA01228F
I2	IECEEx: Ex ia IIC T6-T1 Ga/Gb IECEEx: Ex ia IIIC Txx°C Da/Db	<ul style="list-style-type: none"> <li>▪ FMR56</li> <li>▪ FMR57</li> </ul>	XA00683F	XA00683F	XA01235F	XA00691F	-
I3	IECEEx: Ex d [ia] IIC T6-T1 Ga/Gb IEXEx: Ex ta IIIC Txx°C Da/Db	<ul style="list-style-type: none"> <li>▪ FMR56</li> <li>▪ FMR57</li> </ul>	XA00684F	XA00684F	XA00684F	XA00692F	XA01236F
KA	KC Ex ia IIC T6 Ga	<ul style="list-style-type: none"> <li>▪ FMR56</li> <li>▪ FMR57</li> </ul>	XA01045F	XA01045F	XA01045F	XA01047F	-
KB	KC Ex ia IIC T6 Ga/Gb	<ul style="list-style-type: none"> <li>▪ FMR56</li> <li>▪ FMR57</li> </ul>	XA01045F	XA01045F	XA01045F	XA01047F	-
KC	KC Ex d[ia] IIC T6	<ul style="list-style-type: none"> <li>▪ FMR56</li> <li>▪ FMR57</li> </ul>	XA01046F	XA01046F	XA01046F	XA01048F	XA01046F
MA	INMETRO: Ex ia IIC T6 Ga	<ul style="list-style-type: none"> <li>▪ FMR56</li> <li>▪ FMR57</li> </ul>	XA01286F	XA01287F	XA01288F	XA01296F	-
ME	INMETRO: Ex t IIIC Da	<ul style="list-style-type: none"> <li>▪ FMR56</li> <li>▪ FMR57</li> </ul>	XA01295F	XA01295F	XA01295F	XA01299F	XA01295F

Feature 010	Approval	Available for	Feature 020 "Power Supply; Output"				
			A <sup>1)</sup>	B <sup>2)</sup>	C <sup>3)</sup>	E <sup>4)</sup> /G <sup>5)</sup>	K <sup>6)</sup> /L <sup>7)</sup>
MH	INMETRO; Ex ic IIC T6 Gc	<ul style="list-style-type: none"> <li>■ FMR56</li> <li>■ FMR57</li> </ul>	XA01289F	XA01290F	XA01291F	XA01297F	-
NA	NEPSI Ex ia IIC T6 Ga	<ul style="list-style-type: none"> <li>■ FMR56</li> <li>■ FMR57</li> </ul>	XA01199F	XA01199F	XA01199F	XA01208F	-
NB	NEPSI Ex ia IIC T6 Ga/Gb	<ul style="list-style-type: none"> <li>■ FMR56</li> <li>■ FMR57</li> </ul>	XA01199F	XA01199F	XA01199F	XA01208F	-
NC	NEPSI Ex d[ia] IIC T6 Ga/Gb	<ul style="list-style-type: none"> <li>■ FMR56</li> <li>■ FMR57</li> </ul>	XA01202F	XA01202F	XA01202F	XA01211F	XA01202F
NF	NEPSI DIP A20/21 T85...90oC IP66	<ul style="list-style-type: none"> <li>■ FMR56</li> <li>■ FMR57</li> </ul>	XA01204F	XA01204F	XA01204F	XA01213F	XA01204F
NG	NEPSI Ex nA II T6 Gc	<ul style="list-style-type: none"> <li>■ FMR56</li> <li>■ FMR57</li> </ul>	XA01201F	XA01201F	XA01201F	XA01210F	XA01201F
NH	NEPSI Ex ic IIC T6 Gc	<ul style="list-style-type: none"> <li>■ FMR56</li> <li>■ FMR57</li> </ul>	XA01201F	XA01201F	XA01201F	XA01210F	XA01201F
N2	NEPSI Ex ia IIC T6 Ga/Gb, Ex iaD 20/21 T85...90oC	<ul style="list-style-type: none"> <li>■ FMR56</li> <li>■ FMR57</li> </ul>	XA01205F	XA01205F	XA01205F	XA01214F	-
N3	NEPSI Ex d[ia] IIC T6 Ga/Gb, DIP A20/21 T85...90oC IP66	<ul style="list-style-type: none"> <li>■ FMR56</li> <li>■ FMR57</li> </ul>	XA01206F	XA01206F	XA01206F	XA01215F	XA01206F
8A	FM/CSA IS+XP Cl.I,II,III Div.1 Gr.A-G	<ul style="list-style-type: none"> <li>■ FMR56</li> <li>■ FMR57</li> </ul>	<ul style="list-style-type: none"> <li>■ XA01112F</li> <li>■ XA01113F</li> <li>■ XA01116F</li> <li>■ XA01117F</li> </ul>	<ul style="list-style-type: none"> <li>■ XA01112F</li> <li>■ XA01113F</li> <li>■ XA01116F</li> <li>■ XA01117F</li> </ul>	<ul style="list-style-type: none"> <li>■ XA01112F</li> <li>■ XA01113F</li> <li>■ XA01116F</li> <li>■ XA01117F</li> </ul>	<ul style="list-style-type: none"> <li>■ XA01114F</li> <li>■ XA01115F</li> <li>■ XA01118F</li> <li>■ XA01119F</li> </ul>	-

- 1) 2-wire; 4-20mA HART
- 2) 2-wire; 4-20mA HART, switch output
- 3) 2-wire; 4-20mA HART, 4-20mA
- 4) 2-wire; FOUNDATION Fieldbus, switch output
- 5) 2-wire; PROFIBUS PA, switch output
- 6) 4-wire 90-253VAC; 4-20mA HART
- 7) 4-wire 10.4-48VDC; 4-20mA HART

 For certified devices the relevant Safety Instructions (XA) are indicated on the nameplate.

If the device is prepared for the remote display FHX50 (product structure: feature 030: Display, Operation", option L or M), the Ex marking of some certificates changes according to the following table<sup>13)</sup>:

Feature 010 ("Approval")	Feature 030 ("Display, Operation")	Ex marking
BE	L or M	ATEX II 1D Ex ta [ia] IIIC T <sub>500</sub> xx°C Da
BF	L or M	ATEX II 1/2 D Ex ta [ia Db] IIIC Txx°C Da/Db
BG	L or M	ATEX II 3G Ex nA [ia Ga] IIC T6 Gc
BH	L or M	ATEX II 3G Ex ic [ia Ga] IIC T6 Gc
B3	L or M	ATEX II 1/2G Ex d [ia] IIC T6 Ga/Gb, ATEX II 1/2D Ex ta [ia Db] IIIC Txx°C Da/Db
IE	L or M	IECEX Ex ta [ia] IIIC T500 xx°C Da
IF	L or M	IECEX ta [ia Db] IIIC Txx°C Da/Db
IG	L or M	IECEX Ex nA [ia Ga] IIC T6 Gc
IH	L or M	IECEX Ex ic [ia Ga] IIC T6 Gc

13) The marking of certificates not mentioned in this table are not affected by the FHX50.

Feature 010 ("Approval")	Feature 030 ("Display, Operation")	Ex marking
I3	L or M	IECEX Ex d [ia] IIC T6 Ga/Gb, IECEX Ex ta [ia Db] IIIC Txx°C Da/Db
ME	L or M	Ex ta [ia] IIIC T <sub>500</sub> xx°C Da
MH	L or M	Ex ic [ia Ga] IIC T6 Gc
NF	L or M	NEPSI DIP A20/21 [ia D] TA, Txx°C IP6X
NG	L or M	NEPSI Ex nA [ia Ga] IIC T6-T1 Gc
NH	L or M	NEPSI Ex ic [ia Ga] IIC T6-T1 Gc
N3	L or M	NEPSI Ex d [ia] IIC T6-T1 Ga/Gb, DIP A20/21 [ia D] TA, Txx °C IP6X

ТЕХНОДИЗАЙН-М

## Registered trademarks

### HART®

Registered trademark of the HART Communication Foundation, Austin, USA

### PROFIBUS®

Registered trademark of the PROFIBUS User Organization, Karlsruhe, Germany

### FOUNDATION™ Fieldbus

Registered trademark of the Fieldbus Foundation, Austin, Texas, USA

### KALREZ®, VITON®

Registered trademark of DuPont Performance Elastomers L.L.C., Wilmington, USA

### TEFLON®

Registered trademark of E.I. DuPont de Nemours & Co., Wilmington, USA

### TRI CLAMP®

Registered trademark of Alfa Laval Inc., Kenosha, USA

## Patents

This product may be protected by at least one of the following patents.

Further patents are pending.

US Patents	EP Patents
5.948.979	882 957
6.087.978	955 527
6.140.940	-
6.155.112	834 722
-	882 955
6.266.022	1 083 413
6.295.874	210 567
6.512.358	1 301 914
6.606.904	-
6.640.628	-
6.679.115	1 360 523
-	1 389 337
6.779.397	-
7.201.050	-
7.412.337	-
7.552.634	-
7.730.760	-
7.819.002	-
-	1 774 616
7.966.141	-
8.040.274	-
8.049.371	-



---

ТЕХНОДИЗАЙН-М

ТЕХНОДИЗАЙН-М



71282561

[www.addresses.endress.com](http://www.addresses.endress.com)

---